



C7520196



SCRUBBING MACHINES

USE AND MAINTENANCE MANUAL



CONTENTS

CONTENTS	3
GENERAL SAFETY REGULATIONS	5
SYMBOLS USED IN THE MANUAL	5
LOCATION OF THE MAIN MACHINE COMPONENTS	6
<i>ESSENTIAL VERSION CONTROL PANEL COMPONENTS</i>	7
<i>BRIGHT VERSION CONTROL PANEL COMPONENTS</i>	7
GENERAL DESCRIPTION	8
<i>PURPOSE AND CONTENT OF THE MANUAL</i>	8
<i>TARGET GROUP</i>	8
<i>STORING THE USE AND MAINTENANCE MANUAL</i>	8
<i>ON CONSIGNMENT OF THE MACHINE</i>	8
<i>INTRODUCTORY COMMENT</i>	8
<i>IDENTIFICATION DATA</i>	8
<i>TECHNICAL DESCRIPTION</i>	8
<i>INTENDED USE</i>	8
<i>SAFETY</i>	8
<i>CONVENTIONS</i>	8
<i>LABELS USED ON THE MACHINE</i>	9
<i>SYMBOLS USED ON THE MACHINE</i>	10
<i>SERIAL NUMBER PLATE</i>	11
<i>HANDLING THE PACKAGED MACHINE</i>	11
<i>HOW TO UNPACK THE MACHINE</i>	11
<i>HOW TO MOVE THE MACHINE</i>	11
TECHNICAL DATA	12
<i>GENERAL MACHINE DATA</i>	12
<i>GENERAL MACHINE PERFORMANCE</i>	12
<i>SCRUBBING SYSTEM PERFORMANCE</i>	12
<i>VACUUM HEAD PERFORMANCE</i>	13
<i>TRACTION MOTOR ASSEMBLY PERFORMANCE</i>	13
<i>MACHINE POWER SUPPLY TYPE</i>	13
MACHINE SAFETY MEASURES	13
PREPARATION OF THE MACHINE	14
<i>TYPE OF BATTERY TO BE USED</i>	14
<i>BATTERY MAINTENANCE AND DISPOSAL</i>	14
<i>INSERTING THE BATTERIES IN THE MACHINE</i>	14
<i>RECHARGING THE BATTERIES</i>	14
<i>FILLING THE SOLUTION TANK</i>	15
<i>DETERGENT SOLUTION (VERSION WITHOUT CDS)</i>	15
<i>FILLING THE DETERGENT CANISTER (VERSIONS WITH CDS)</i>	15
<i>INSERTING WATER SYSTEM FILTER</i>	16
<i>ASSEMBLING THE SCRUBBING BRUSH HEAD BODY BRUSHES</i>	16
PREPARING TO WORK	16
WORK	16
<i>DRIVE SELECT SELECTOR</i>	17
<i>HOURLY METER (ESSENTIAL VERSIONS)</i>	18
<i>HOURLY METER (BRIGHT VERSIONS)</i>	18

BATTERY CHARGE LEVEL INDICATOR (ESSENTIAL VERSIONS).....	18
BATTERY CHARGE LEVEL INDICATOR (BRIGHT VERSIONS).....	18
SELECTING THE OPERATING DIRECTION.....	19
ADJUSTING THE OPERATING SPEED.....	19
BUZZER.....	19
ADJUSTING THE FLOW OF DETERGENT SOLUTION (ESSENTIAL VERSIONS).....	20
ADJUSTING THE WORKING PARAMETERS (BRIGHT VERSIONS IN MANUAL MODE).....	20
BRUSH HEAD BODY LATERAL MOVEMENT FUNCTION (ESSENTIAL VERSIONS).....	21
AUTOMATIC DETERGENT DOSING FUNCTION (ESSENTIAL VERSIONS WITH CDS).....	21
BRUSH HEAD BODY LATERAL MOVEMENT FUNCTION (BRIGHT VERSIONS).....	21
WORKING HEADLIGHTS FUNCTION (ESSENTIAL VERSIONS).....	21
EXTRA PRESSURE FUNCTION (ESSENTIAL VERSIONS).....	21
WORKING HEADLIGHTS FUNCTION (BRIGHT VERSIONS).....	21
AUTOMATIC DETERGENT DOSING SYSTEM FUNCTION (BRIGHT VERSIONS).....	22
COURTESY LIGHTS (OPTIONAL).....	22
REAR VIDEO CAMERA (BRIGHT VERSION).....	22
EMERGENCY STOP BUTTON.....	22
ANTI-COLLISION SYSTEM (BRIGHT VERSIONS).....	23
ALARM SCREEN.....	23
BRAKING CONTROL.....	24
LIQUID VACUUM WAND KIT (OPTIONAL).....	24
SOLUTION TANK CAPACITY LOW.....	24
DETERGENT TANK CAPACITY LOW.....	24
TANK CLEANING KIT (OPTIONAL).....	25
PERIODIC MAINTENANCE FUNCTION.....	26
AT THE END OF THE WORK.....	26
RECOMMENDED MAINTENANCE OPERATIONS.....	27
CLEANING THE SQUEEGEE BODY.....	27
CLEANING THE SCRUBBING BRUSH HEAD LATERAL SPLASH GUARD RUBBER BLADES.....	28
CLEANING THE SCRUBBING BRUSH HEAD BODY BRUSHES.....	28
DRAINING THE RECOVERY TANK.....	28
CLEANING THE RECOVERY TANK FILTERS.....	28
EMPTYING THE SOLUTION TANK.....	29
CLEANING THE WATER SYSTEM FILTER.....	29
CLEANING THE VACUUM TUBE.....	29
EXTRAORDINARY MAINTENANCE WORK.....	30
REPLACING THE SQUEEGEE BODY RUBBER BLADES.....	30
REPLACING THE SCRUBBING BRUSH HEAD BODY SPLASH GUARD.....	30
REPLACING THE SCRUBBING BRUSH HEAD BODY BRUSHES.....	31
ADJUSTMENT INTERVENTIONS.....	31
ADJUSTING THE SQUEEGEE BODY RUBBER BLADES.....	31
ADJUSTING THE SCRUBBING BRUSH HEAD SIDE SPLASH GUARD.....	32
DISPOSAL.....	32
CHOOSING AND USING THE BRUSHES.....	33
TROUBLESHOOTING.....	34
EC DECLARATION OF CONFORMITY.....	36















The descriptions contained in this document are not binding. The company therefore reserves the right to make any modifications at any time to elements, details, or accessory supply, as considered necessary for reasons of improvement or manufacturing/commercial requirements. The reproduction, even partial, of the text and drawings contained in this document is prohibited by law.

The company reserves the right to make any technical and/or supply modifications. The images are shown as reference only and are not binding as to the actual design and/or equipment.

GENERAL SAFETY REGULATIONS

Before using the machine, please read the following document carefully and follow the instructions contained herein, along with the instructions in the document supplied with the machine itself, "GENERAL SAFETY REGULATIONS" (document code 10083659).

SYMBOLS USED IN THE MANUAL

	Symbol of the open book with i: Indicates the need to consult the instruction manual.
	Symbol of the open book: Tells the operator to read the user manual before using the device.
	Covered place symbol: the operations preceded by this symbol must always be carried out in a dry, covered area.
	Information symbol: Indicates additional information for the operator, to improve the use of the device.
	Warning symbol: Carefully read the sections preceded by this symbol meticulously following the instructions indicated for the safety of the operator and the device.
	Danger symbol (corrosive substances): The operator should always wear protective gloves to avoid the risk of serious injury to the hands caused by corrosive substances.
	Danger symbol (battery acid leakage): Indicates the danger of leaking acid or acid fumes from the batteries while they are being recharged.
	Danger symbol (moving carriages): Indicates that the packed product should be handled with suitable carriages that conform to legal requirements.
	Mandatory room ventilation symbol: Informs the operator that the room must be ventilated while the batteries are being recharged.
	Symbol indicating the compulsory use of protective gloves: Indicates that the operator should always wear protective gloves, to avoid the risk of serious injury to his hands from sharp objects.
	Symbol indicating the compulsory use of tools: Informs the operator of the need to use tools not included with the machine.
	Symbol indicating a treading ban: Informs the operator that it is forbidden to tread on machine components, as this could lead to serious injury.
	Recycling symbol: Tells the operator to carry out the operations in compliance with environmental regulations in force in the place where the appliance is being used.
	Disposal symbol: Carefully read the sections marked with this symbol for disposing of the appliance.

LOCATION OF THE MAIN MACHINE COMPONENTS

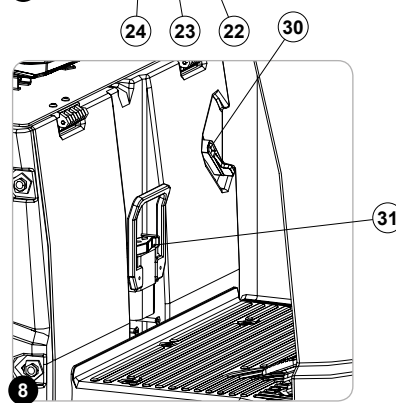
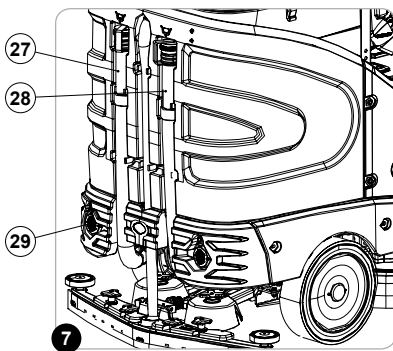
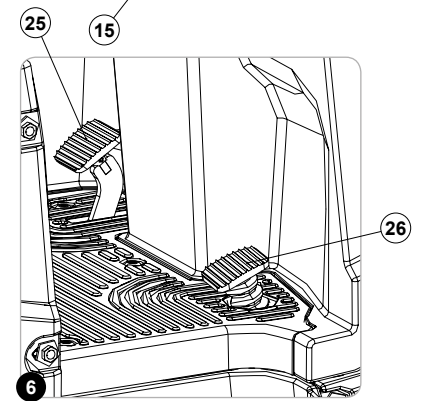
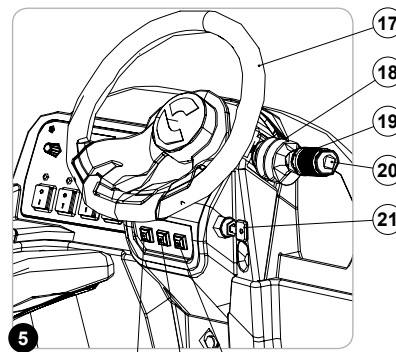
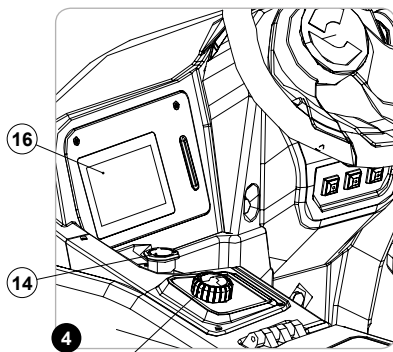
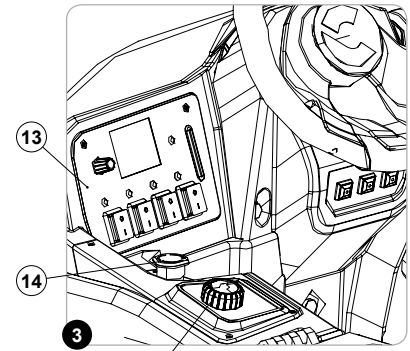
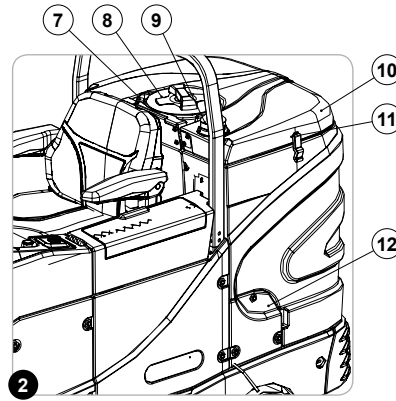
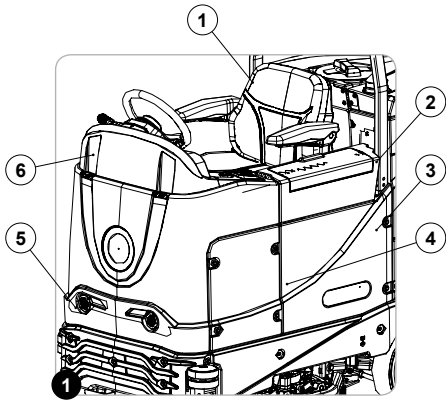

The main machine components are the following:

1. Seat
2. Storage compartment cover, or liquid vacuum wand holder compartment if the version of the machine is in equipped with this
3. Battery compartment carter
4. Electrical system panel carter
5. Front headlights
6. Instrument panel carter
7. Continuous float kit (valid for Bright versions)
8. Water filler cap
9. Blinking light
10. Tank cover
11. Tank cover closure hook
12. Suction motor carter
13. Control panel (valid for Essential versions)
14. Emergency button
15. Working program selector (Drive Select)
16. Control panel (valid for Bright versions)
17. Steering wheel
18. Travel direction selector lever
19. Forward speed selector knob
20. Buzzer button
21. Main key switch
22. Liquid vacuum wand kit control button (valid for Essential versions)
23. Maintenance lights control button
24. Spray gun kit control button (valid for Essential versions)
25. Brake pedal
26. Forward drive pedal
27. Detergent solution compartment drainage tube
28. Recovery solution compartment drainage tube
29. Rear headlights
30. Detergent solution flow adjustment lever
31. Battery connector

ESSENTIAL VERSION CONTROL PANEL COMPONENTS

The control panel components on the Essential version are as follows:

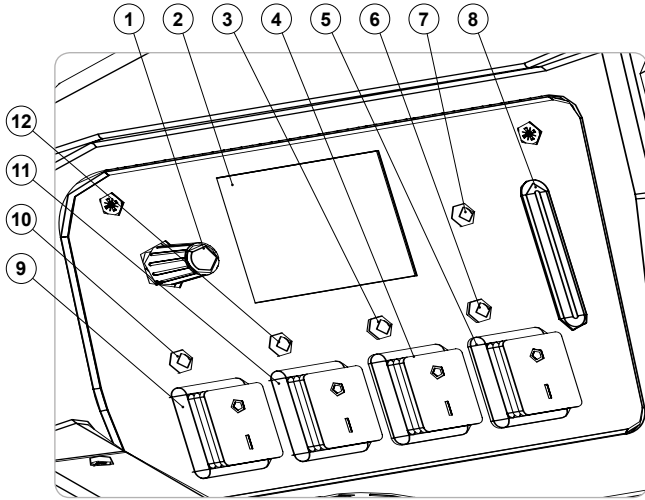

1. Detergent solution flow adjustment knob
2. Command display
3. Green indicator light signalling activation of brush head body lateral movement
4. Command switch for brush head body lateral movement
5. Detergent pump command switch
6. Green indicator light signalling activation of detergent pump (valid for versions with automatic detergent dosing kit)
7. Red indicator light signalling low detergent solution level (valid for versions without automatic detergent dosing kit), or low water level warning (valid for versions with automatic detergent dosing kit)
8. Badge insertion slot (valid for versions with the "COMAC FLEET CARE" system)
9. Working headlights command switch
10. Green indicator light signalling activation of working headlights
11. Command switch for activation of brush head body extra pressure function
12. Green indicator light signalling activation of brush head body extra pressure function

BRIGHT VERSION CONTROL PANEL COMPONENTS

The control panel components on the Bright version are as follows:

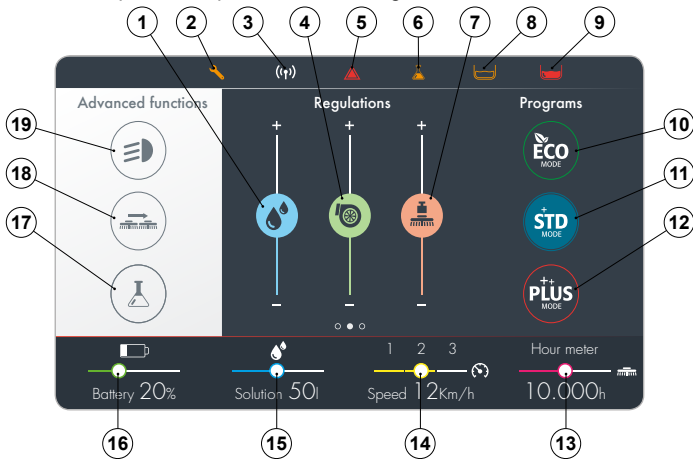

1. Flow adjustment indicator for detergent solution in the machine water system.
2. Maintenance due symbol; if this is visible, this indicates that the scheduled maintenance is due to be performed.
3. CFC symbol; if visible, this shows that the "COMAC FLEET CARE" system is connected.
4. Suction motor efficiency adjustment indicator.
5. General alarm symbol; when an error occurs, the symbol appears, and remains visible until the error in question is resolved.
6. Detergent tank empty float symbol, only valid for machine versions with integrated CDS (COMAC DOSING SYSTEM).
7. Weight exerted on the brush head adjustment indicator.
8. Solution tank empty float symbol.
9. Recovery tank full float symbol.
10. ECO MODE working program activation - deactivation button.
11. STANDARD MODE working program activation - deactivation button.
12. PLUS MODE working program activation - deactivation button.

13. Hour meter.
14. Current speed indicator.
15. Tank solution level indicator (valid for versions with the continuous float kit).
16. Battery charge level indicator.
17. COMAC DOSING SYSTEM activation - deactivation button.
18. Brush head body lateral movement activation - deactivation button.
19. Working headlights activation - deactivation button.

GENERAL DESCRIPTION

PURPOSE AND CONTENT OF THE MANUAL

The aim of this manual is to provide customers with all the information needed to use the machine in the safest, most appropriate and most autonomous way. This includes information concerning technical aspects, safety, operation, downtime, maintenance, spare parts and scrapping. The operators and qualified technicians must carefully read the instructions in this manual before carrying out any operations on the machine. If in doubt about the correct interpretation of instructions, contact your nearest Customer Service Centre to obtain the necessary clarifications.

TARGET GROUP

This manual is written both for operators and for qualified machine maintenance technicians. Operators must not perform operations that should be carried out by qualified technicians. The manufacturer is not liable for damages resulting from failure to comply with this veto.

STORING THE USE AND MAINTENANCE MANUAL

The Use and Maintenance Manual must be stored in its special pouch close to the machine, protected from liquids and anything else that could compromise its legibility.

ON CONSIGNMENT OF THE MACHINE

When the machine is consigned to the customer, an immediate check must be performed to ensure all the material mentioned in the shipping documents has been received, and also to check the machine has not suffered damage during transportation. If this is the case, the carrier must ascertain the extent of the damage at once, informing our customer service office. It is only by prompt action of this type that the missing material can be obtained, and compensation for damage successfully claimed.

INTRODUCTORY COMMENT

Any floor scrubbing machine can only work properly and effectively if used correctly and kept in full working order by performing the maintenance operations described in the attached documentation. We therefore suggest you read this instruction booklet carefully and read it again whenever difficulties arise while using the machine. If necessary, remember that our assistance service (organised in collaboration with our dealers) is always available for advice or direct intervention.

IDENTIFICATION DATA

For technical assistance or to request replacement parts, always give the model, the version and the serial number (written on the relevant plate).

TECHNICAL DESCRIPTION

The **C75 2019 Bis** is a floor scrubbing machine that can handle a wide variety of floors and types of dirt by using the mechanical action of two disc brushes and the chemical action of a water-detergent solution. As it advances, it collects the dirt removed and the detergent solution not absorbed by the floor. **The machine must only be used for this purpose.**

INTENDED USE

This scrubbing machine was designed and built for the cleaning (scrubbing and drying) of smooth, compact flooring in the commercial, residential and industrial sectors by a qualified operator in proven safety conditions. The scrubbing machine is not suitable for cleaning rugs or carpet floors. It is only suitable for use in closed (or at least covered) places.

 **ATTENTION:** *the machine is not suitable for use in the rain, or under water jets.*

 **IT IS FORBIDDEN** to use the machine for picking up dangerous dusts or inflammable liquids in places with an explosive atmosphere. In addition, it is not suitable as a means of transport for people or objects.











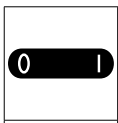

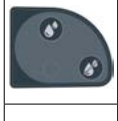



SAFETY

Operator cooperation is paramount for accident prevention. No accident prevention program can be effective without the full cooperation of the person directly responsible for machine operation. The majority of occupational accidents that happen either in the workplace or whilst moving are caused by failure to respect the most basic safety rules. An attentive, careful operator is most effective guarantee against accidents and is fundamental in order to implement any prevention program.

CONVENTIONS

All references to forwards and backwards, front and rear, right and left indicated in this manual should be understood as referring to the operator in a driving position with his hands on the steering wheel.

LABELS USED ON THE MACHINE

	<p>Main switch symbol: Applied to the control panel, positioned on the front of the machine, to indicate the main switch.</p>
	<p>Acoustic signalling device control label: Applied in the vicinity of the steering column to indicate the acoustic signalling device's control button.</p>
	<p>Label for detergent solution tap control: Applied in the vicinity of the control column to identify the detergent solution tap control lever.</p>
	<p>Label indicating the need to read the Use and Maintenance Manual: Applied in the vicinity of the steering column in order to remind the operator to read the user and maintenance manual before using the machine.</p>
	<p>Treading ban label: Located on the machine, to identify the surfaces that must not be trodden on (risk of personal injury or damage to the machine).</p>
	<p>Label warning about the risk of crushed hands: Indicates danger to hands due to crushing between two surfaces.</p>
	<p>Warning label: Attached to the machine in order to warn the operator to read the user and maintenance manual (this document) before using the machine for the first time.</p>
	<p>Forbidden to vacuum - collect label: Attached to the machine in order to warn the operator that it is forbidden to use the machine to collect and/or vacuum powders and/or liquids that are flammable and/or explosive, or incandescent particles.</p>
	<p>Battery charging warning label: Affixed to the machine to advise the operator how to recharge the batteries.</p>
	<p>Battery charging warning label: Affixed to the machine to warn the operator of the danger of leakage of flammable gases during battery charging.</p>
	<p>Solution tank filter daily care warning label: Applied to the machine to remind the operator to clean the solution tank after each use.</p>
	<p>Suction motor filter label: Applied inside the vacuum cover to identify the suction motor intake air filter, and also serves to remind the operator to clean the filter after each machine use.</p>
	<p>Braking system oil level check label: Located near the braking system oil basin, to remind the operator to check the level of oil in the basin. The bottom part of the label shows the recommended oil for the braking system.</p>
	<p>Service brake pedal positioning label: Affixed to the machine to indicate the position of the service brake pedal.</p>
	<p>Label indicating maximum temperature for filling the solution tank: Located on the upper part of the solution tank, to indicate the maximum temperature of the water for filling the solution tank safely.</p>
	<p>Scrubbing brush head in motion danger warning label: Affixed to the brush head to warn the operator that the brush head could move sideways.</p>



Label indicating machine direction selector button:

Affixed near the steering wheel to indicate how to move the machine travel direction control lever.



Courtesy lights (optional) control label:

Affixed near the steering wheel to indicate the position of the courtesy lights control button.



Spray gun (optional) position label:

Affixed to the rear of the machine to identify the spray gun support.



Liquid vacuum wand kit (optional) position label:

Affixed to the machine to identify the liquid vacuum wand holder compartment.



Label indicating the position of the detergent tank (CDS versions):

Affixed to the machine to indicate the position of the detergent tank.



Label indicating positioning of the cornering speed adjustment sensor:

Affixed to the machine to explain how to correctly position the sensor which enables machine speed around corners to be reduced.



Label indicating percentage of detergent use (CDS versions):

Affixed near the detergent tank to indicate the usage instructions for standard or concentrated detergents.



Water system usage warning label (CDS versions):

Affixed to the machine in order to warn the operator to read the user and maintenance manual (this document) before using the appliance with the automatic detergent solution dosing system.



pH label (CDS versions):

Affixed above the detergent tank to indicate the pH range of the detergent to be utilized.

SYMBOLS USED ON THE MACHINE



Recovery tank drainage hose symbol:

Applied to the back of the machine to identify the recovery tank drainage tube.



Solution tank drainage cap symbol:

Applied to the back of the machine to identify the solution tank drainage cap.

SERIAL NUMBER PLATE

The serial number plate is located at the rear of the steering column, and indicates the machine's general characteristics, including its serial number. The serial number is a very important piece of information and should always be provided together with any request for assistance or to purchase spare parts. The serial number plate contains the following:

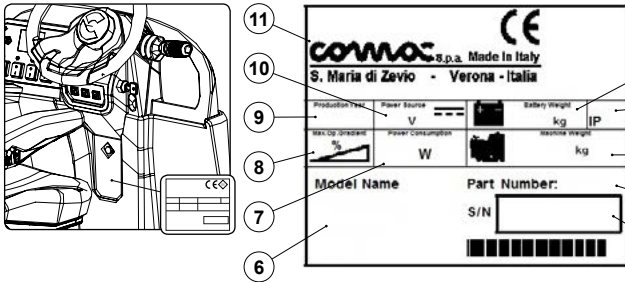

1. The weight of the batteries used to power the appliance (expressed in Kg).
2. The IP protection rating of the appliance.
3. The gross weight of the appliance (expressed in kg).
4. The identification code of the appliance.
5. The serial number of the appliance.
6. The name of the appliance.
7. The nominal power consumed by the appliance (expressed in W).
8. The maximum grade that the appliance can handle during work activities (expressed as %).
9. The year in which the appliance was manufactured.
10. The nominal voltage of the appliance (expressed in V).
11. The commercial name of the appliance and the manufacturer's address.

HANDLING THE PACKAGED MACHINE

The machine's overall weight including packaging is 615kg. The overall dimensions of the package are: length = 000cm width = 000cm height = 000cm

ATTENTION: It is recommended that all the packaging components be kept for any future machine transportation.

ATTENTION: Move the packaged product with handling equipment that complies with legal requirements regarding the size and mass of the packaging.

HOW TO UNPACK THE MACHINE

The machine is shipped in specific packaging. To remove it, proceed as follows:

1. Place the lower part of the outer packaging in contact with the floor.

N.B.: use the pictograms printed on the box as a reference.

2. Remove the outer package.

WARNING: the machine is contained in specific packaging materials, whose elements (plastic bags, staples, etc.) can pose potential hazards, and must not be left within reach of children, disabled persons, etc.

CAUTION: it is recommended to wear the appropriate PPE (Personal Protective Equipment) for the work to be carried out.

3. Insert a ramp in the rear part of the machine.

ATTENTION: the ramp gradient must not be such as to cause damage to the machine as it comes down.

4. The machine is fastened to the platform with wedges, remove these wedges.
5. Take the machine off the pallet via the ramp.

CAUTION: during this operation, check there are no people or objects near the machine.

HOW TO MOVE THE MACHINE

To transport the machine safely, proceed as follows:

1. Make sure that the solution tank and the recovery tank are empty. If not, empty them (see the sections "[EMPTYING THE SOLUTION TANK](#)" and "[EMPTYING THE RECOVERY TANK](#)").
2. Place the machine on the transport vehicle.

WARNING: secure the device according to the directives in force in the country of use (ex. 2014/47/EU), so that it cannot slide or tip over.

TECHNICAL DATA

GENERAL MACHINE DATA

DESCRIPTION	U/M [KMS]	C75 2019 B
Nominal input power [IEC 60335-2-72; IEC 62885-9]	kW	3,4
Solution tank capacity [IEC 62885-9]	l	140
Recovery tank capacity [IEC 62885-9]	l	140
Maximum solution tank capacity	l	10.5
Minimum inversion corridor [IEC 62885-9]	mm	2234
Machine dimensions during work (length x height x width)	mm	1813 1591 985
Machine dimensions during transport [IEC 62885-9]	mm	862
Battery compartment dimensions (length x height x width)	mm	535 515 620
Machine net weight [IEC 62885-9]	kg	425
Machine weight during transport [IEC 62885-9]	kg	774
GVW [IEC 60335-2-72; IEC 62885-9]	kg	1059
Maximum specific pressure on wheels [IEC 62885-9]	N/mm ²	0,91
Sound pressure level in operator seat [ISO 11201] (L _{pA})	dB	69,9
Uncertainty K _{pA}	dB	1,5
Sound power level [IEC 60335-2-72; IEC 62885-9; ISO 3744] (L _{WA})	dB	70,2
Hand-arm vibrations [IEC 60335-2-72; IEC 62885-9; ISO 5349-1]	m/s ²	1
Whole body vibrations [IEC 60335-2-72; IEC 62885-9; ISO 2631-1]	m/s ²	0,36
Vibration uncertainty	%	±4%
IP test [IEC 60335-2-72; IEC 60529]		23
Electrical protection class [IEC 60335-2-72; IEC 60335-1]		III

GENERAL MACHINE PERFORMANCE

DESCRIPTION	U/M [KMS]	C75 2019 B
Productivity theoretical	sq.m./h	6083
Estimated coverage	sq.m./h	5005
Gradeability on uphill slope (transfer mode; transported machine weight)	%	17
Gradeability on uphill slope (work mode; GVW machine weight)	%	20
Time taken to empty recovery tank [IEC 62885-9]	min.	2
Water consumption [IEC 62885-9]	ml/m ²	-
Maximum ambient temperature for correct machine operation during scrubbing phase	°C	+40
Maximum ambient temperature for correct machine operation during scrubbing phase	°C	+5

SCRUBBING SYSTEM PERFORMANCE

DESCRIPTION	U/M [KMS]	C75 2019 B
Working width [IEC 62885-9]	mm	770
Lateral movement of the brush head body	mm	90
Nominal power of brush motor/s [IEC 62885-9]	W	2 x 750
Total width of brushes [IEC 62885-9]	mm	2 x 400
Maximum free brush rotations	rpm	190
Maximum force exerted by the brush head on the floor	N	1079
Maximum pressure exerted by the brush head on the floor	N/cm ²	1,19
Maximum detergent solution flow [IEC 62885-9]	l/min	5,3

VACUUM HEAD PERFORMANCE

DESCRIPTION	U/M [KMS]	C75 2019 B
Squeegee width	mm	985
Drying track [IEC 62885-9]	mm	960
Nominal power of vacuum motor(s) [IEC 62885-9]	W	650
Maximum vacuum [IEC 62885-9; IEC 60312-1]	kPa	18,5
Maximum air flow [IEC 62885-9]	l/s	18,8

TRACTION MOTOR ASSEMBLY PERFORMANCE

DESCRIPTION	U/M [KMS]	C75 2019 B
Nominal power of traction motor [IEC 62885-9]	W	1200
Maximum speed possible (transfer mode; transported machine weight) [IEC 62885-9]	km/h	8,3
Maximum speed possible (work mode; GVW machine weight)	km/h	6,5

MACHINE POWER SUPPLY TYPE

DESCRIPTION	U/M [KMS]	C75 2019 B
Battery box capacity (C_5) [IEC 62885-9]	Ah _{C5}	320
Battery box charging time DOD 60%	hh:mm	08:20

Notes

The battery box used during the data collection phase was a 36V 320Ah_{C5} box

The battery charger used was:

MACHINE SAFETY MEASURES

The procedure for securing the machine, thus allowing the operations to be performed under conditions of complete safety, is as follows:

1. Sit on the driver's seat.
2. Insert the key into the main switch on the control panel. Set the main switch to "I" by turning the key a quarter turn clockwise (**Fig.1**).
3. Using the i-drive control knob (**Fig.2**), select the "transfer" program (see "[DRIVE SELECT SELECTOR](#)").

(i) N.B.: in this way, both the brush head body and the squeegee body will move to their idle position.

4. Shift the direction lever to the "idle" position, moving it in the direction shown by the arrow (**Fig.3**).
5. Move the main switch to the "0" position by turning the key a quarter turn anti-clockwise (**Fig.4**). Remove the key from the main switch.
6. Disconnect the battery connector from the machine's main system connector (**Fig.5**).

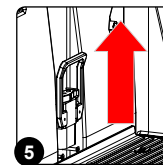
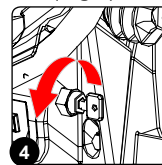
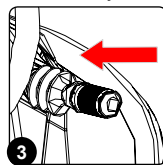
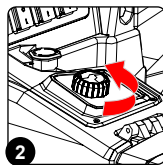
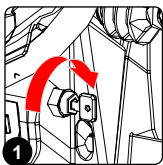

PREPARATION OF THE MACHINE

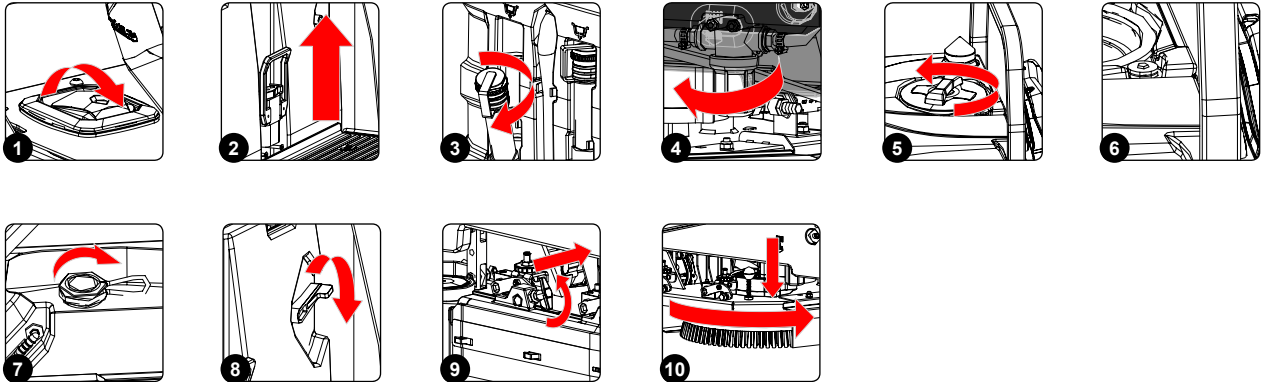

TYPE OF BATTERY TO BE USED

The batteries must meet the requirements laid out in the norms: DIN/EN 60254-2 and IEC 254-2 series L. **To carry out the work well the machine must have a 36V power supply**, we recommend using a 36V 360Ah/C₅ traction battery box.

BATTERY MAINTENANCE AND DISPOSAL

For battery maintenance and recharging, respect the instructions provided by the battery manufacturer. When the batteries reach the end of their working life, they must be disconnected by expert, trained personnel then removed from the battery compartment with the aid of suitable lifting devices.



N.B.: dead batteries are classified as dangerous waste and as such must be delivered to an authorised body for disposal.

INSERTING THE BATTERIES IN THE MACHINE

To fit the batteries inside the machine, contact an COMAC assistance centre technician.



WARNING: COMAC declines all responsibility for any damage to property or injury persons in the event that the batteries are replaced by an unauthorized technician.

RECHARGING THE BATTERIES

The batteries must be charged prior to the first use, and when they don't provide enough power for tasks that could formerly be performed without difficulty.



ATTENTION: to avoid any permanent damage to the batteries, it is essential to avoid their complete discharge; begin recharging them within a few minutes of noting the "discharged batteries" signal.



ATTENTION: never leave the batteries completely run down, even if the machine is not being used.

To recharge the batteries, proceed as follows:

1. Bring the appliance to the area where the batteries are charged.



N.B.: Park the machine in an enclosed place, on a flat and level surface; near the machine there must be no objects that could either damage it, or be damaged through contact with it.



WARNING: the battery recharging area must comply with the requisites of Standard CEI EN 50272-3, or those currently in force in the country of use.

2. Make sure the machine is in a safe condition (see chapter "[MACHINE SAFETY MEASURES](#)").
3. Grip the handle for moving the seat mounting plate and turn the plate to the maintenance position (**Fig.1**).
4. Disconnect the battery connector from the machine's main system connector (**Fig.2**).



ATTENTION: the following operations must be carried out by qualified personnel. An incorrect connection of the connector may cause a malfunction of the device.

5. Connect the external battery charger cable to the battery connector.



N.B.: the coupling connector of the battery charger is consigned inside the bag containing this instruction booklet, and must be assembled on the cables of the battery charger as indicated in the instructions.



CAUTION: before connecting the batteries to the battery charger, make sure it is suitable for the batteries used.



CAUTION: carefully read the Use and Maintenance Manual of the battery charger used for recharging.



CAUTION: keep the battery inspection carter open for the duration of the battery recharging cycle to allow gas fumes to escape.

6. When the recharge cycle is complete, disconnect the external battery charger cable from the battery connector.
7. Connect the battery connector to the machine's main system connector.
8. Grip the handle and turn the seat mounting plate to its working position.

FILLING THE SOLUTION TANK

Before filling the solution tank, carry out the following steps:

1. Take the machine to the usual place for filling the solution tank.
2. Make sure the machine is in a safe condition (see chapter "[MACHINE SAFETY MEASURES](#)").
3. Check that the solution tank drainage cap is closed. If this is not the case, close it (**Fig.3**).
4. Check to make sure that the water system filter cap, located on the front left-hand side of the machine, is closed. If this is not the case, close it (**Fig.4**).

The solution tank can be filled with water in two different ways:

- Removing the cap and filling the solution tank by means of a rubber hose or a bucket (**Fig.5**). Remember to check that the filter is correctly positioned above the filler opening.
 - Remove the cap above the quick connector (**Fig.6**). Connect the quick connector on the water hose to the quick connector on the machine; remember to remove the cap to enable the air to be vented correctly.
5. Fill with clean water, at a temperature no higher than 50°C (122°F) and no lower than 10°C (50°F).

DETERGENT SOLUTION (VERSION WITHOUT CDS)

After filling the solution tank with clean water add the liquid detergent to the tank in the concentration and manner indicated on the detergent manufacturer's label. To prevent the formation of an excessive amount of foam that could damage the vacuum motor, use the minimum percentage of detergent required.



CAUTION: it is recommended to wear the appropriate PPE (Personal Protective Equipment) for the work to be carried out.



ATTENTION: always use detergents whose manufacturer's label indicates their suitability for scrubbing machines. Do not use acid or alkaline products or solvents without this indication.



N.B.: always use low-foam detergent. To avoid the production of foam, put a minimum quantity of antifoam liquid in the recovery tank before starting to clean. Do not use pure acids.

FILLING THE DETERGENT CANISTER (VERSIONS WITH CDS)

After filling the solution tank with clean water, proceed as follows:

1. Bring the machine to the area designated for refilling the solution tank.
2. Make sure the machine is in a safe condition (see chapter "[MACHINE SAFETY MEASURES](#)").



CAUTION: it is recommended to wear the appropriate PPE (Personal Protective Equipment) for the work to be carried out.

3. Grip the handle for moving the seat mounting plate and turn the plate to the maintenance position (**Fig.1**).
4. Remove the cap of the filler hose and fill it with the desired detergent (**Fig.7**).



ATTENTION: always use detergents whose manufacturer's label indicates their suitability for scrubbing machines. Do not use acid or alkaline products or solvents without this indication.



ATTENTION: the dosing system is suitable for frequent maintenance cleaning. acid or alkaline maintenance detergents can be used, as long as they have pH values between 4 and 10, and do not contain: oxidising agents, chlorine or bromine, formaldehyde, mineral solvents. The detergents used must be suitable for use with scrubbing machines. Wash the circuit with water after use if the system is not used daily. The system can be excluded. In case of sporadic use of detergents with pH between 1-3 or 11-14, use the floor scrubbing machine in the traditional way by adding the detergent in the clean water tank and excluding the dosing circuit.



ATTENTION: always use low-foam detergent. To avoid the production of foam, put a minimum quantity of antifoam liquid in the recovery tank before starting to clean. Do not use pure acids.

5. Close the cap correctly to prevent liquid leaking out when working.
6. Replace the filler hose inside the retainers.
7. Turn the seat mounting plate to its working position.

INSERTING WATER SYSTEM FILTER

Before using the machine for the first time the water system filter needs to be reset, for shipping reasons the filter cartridge and the cap have been removed. To insert the filter cartridge in the water system filter body proceed as follows:

1. Take the machine to the maintenance area.
2. Make sure the machine has been secured (see the chapter entitled [“SECURING THE MACHINE”](#)).

⚠ CAUTION: it is recommended to wear the appropriate PPE (Personal Protective Equipment) for the work to be carried out.

3. Close the tap output flow and turn the lever positioned near the operator seat in a clockwise direction (**Fig.8**).
4. Insert the filter cartridge in the housing on the cap.

i N.B.: The O-ring gasket in the filter cartridge should be inserted into its seat in the cap.

5. Screw the cap onto the body of the detergent solution filter (**Fig.4**).

ASSEMBLING THE SCRUBBING BRUSH HEAD BODY BRUSHES

To fit the brush on the brush head body, proceed as follows:

1. Take the machine to the maintenance area.
2. Make sure the machine has been secured (see the chapter entitled [“SECURING THE MACHINE”](#)).

⚠ CAUTION: it is recommended to wear the appropriate PPE (Personal Protective Equipment) for the work to be carried out.

3. Go to the left-hand side of the machine and remove the left-hand splash guard, then move the fixing anchors on the brush head body into the maintenance position (**Fig.9**).
4. With the brush head UP, insert the brush in the plate housing underneath the brush head, turning it until the three buttons engage with the notches on the plate itself.
5. Turn in increments until the button is pushed towards the coupling spring and is locked in place (**Fig.10**).

i N.B.: The image in **Fig.10** indicates the direction of rotation for coupling the left brush; the right brush must be turned in the opposite direction.

PREPARING TO WORK

Before beginning to work, it is necessary to:

1. Make sure the recovery tank is empty. If it isn't, empty it (see [“EMPTYING THE RECOVERY TANK”](#)).
2. Check that the quantity of detergent solution in the solution tank is right for the type of work to be carried out. If necessary, fill the tank (for versions without CDS, read [“FILLING THE SOLUTION TANK”](#) and [“DETERGENT SOLUTION \(VERSION WITHOUT CDS\)”](#); for versions with CDS, read [“FILLING THE SOLUTION TANK”](#) and [“FILLING THE DETERGENT CANISTER \(VERSIONS WITH CDS\)”](#)).
3. Check that the squeegee rubbers are in good working condition. If not, carry out maintenance (see [“REPLACING THE SQUEEGEE BODY RUBBER BLADES”](#)).
4. Check that the splash guard rubber blades on the scrubbing brush head body are in good working condition. If this is not the case, replace them (see [“REPLACING THE SCRUBBING BRUSH HEAD BODY SPLASH GUARD”](#)).
5. Check that the brushes are in good working condition. If this is not the case, replace them (see [“REPLACING THE SCRUBBING BRUSH HEAD BODY BRUSHES”](#)).
6. Check that the battery connector is connected to the machine's general system connector; if this is not the case, perform this operation.

WORK

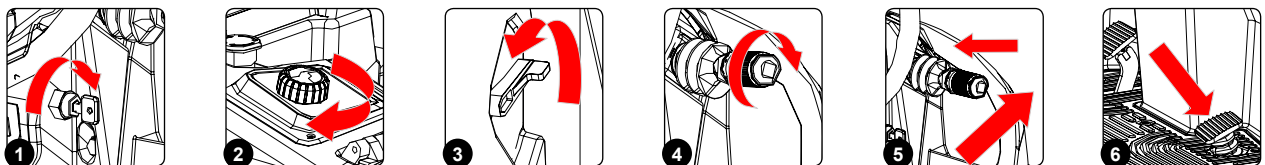

For Bright versions: Three working programs can be selected via the command display, the choice is based on the type of work to be carried out and on the type of dirt to be cleaned, for example:

- Eco program: This program is ideal performing cleaning primarily for maintenance purposes that does not require any particular scrubbing power.
- Standard program: This program is recommended for regular cleaning operations on moderately dirty surfaces.
- Plus program: This program is useful when increased scrubbing power is required on resistant, stubborn dirt since it increases the flow of detergent solution and pressure on the brushes to the maximum.

i **N.B.:** The notes above are purely indicative.

i **N.B. :** To activate the selected program, press the corresponding button; as soon as the button has been pressed, it will be selected, and the symbol background will be filled.

i **N.B. :** To change the parameters for each working program, manual mode must be activated; contact the area service representative.

We will take the Standard mode working program as an example. To start working, proceed as follows:

1. Carry out all the checks listed in the chapter "[PREPARING TO WORK](#)".
2. Sit on the driver's seat.
3. Insert the key into the main switch on the control panel. Set the main switch to "I" by turning the key a quarter turn clockwise (**Fig.1**).

i **N.B.:** As soon as the machine is switched on, the control board will carry out diagnostics on the machine; the buzzer will only give the signal that work can be started if the outcome of this is positive.

4. Turn the knob and select the desired working program (see "[DRIVE SELECT SELECTOR](#)") (**Fig.2**).
5. Open the detergent solution flow into the machine's water system by turning the tap control lever in the direction indicated by the arrow (**Fig.3**).
6. Select the speed level (e.g. "step-01") and turn the handle on the direction selection lever (**Fig.4**) under the steering wheel.

i **N.B.:** adjust the forward speed to suit the adhesion conditions.

7. Select the direction in which you want to move the machine. For example, if you want to move forward, shift the direction selector lever in the direction shown by the arrow (**Fig.5**).

i **N.B.:** To select the forward gear (F) you need to first shift the lever up and then in the direction indicated by the arrow (**Fig.5**).

8. Press the drive pedal to begin moving the machine (**Fig.6**).

If the working mode selected is "SCRUBBING WITH DRYING", the squeegee and brush head will lower until they touch the floor. As soon as the drive pedal is pressed, the traction motor, brush head motor and suction motor will start working. As a result, the solenoid valve will also be activated and detergent solution will be dispensed onto the brushes.

During the first few metres, check that there is sufficient solution and that the squeegee is drying correctly.





The machine will now begin to work with full efficiency until the battery is flat or until the detergent solution has finished.

i **N.B. :** Before cleaning, pick up large pieces of waste. Pick up wire, tape, string, large pieces of wood or other refuse that could wrap around the brushes or become entangled. Drive the machine in a straight line. Avoid hitting obstacles and scratching the sides of the machine. Overlap the cleaning track by a few centimetres. Avoid turning the steering wheel abruptly when the machine is moving. The machine responds rapidly to the movements of the steering wheel. Avoid hairpin turns, except in emergencies. Adjust the speed of the machine, the pressure of the brushes and the flow of the solution according to the type of cleaning to be carried out. Drive the machine slowly on inclines. Use the brake pedal to control the speed when going down an incline. Where there is a slope, carry out the scrubbing by moving the machine upwards rather than downwards.

! **ATTENTION:** when you use the machine, slow down on ramps and slippery surfaces. Do not use the machine in areas where the ambient temperature is higher than 43 °C (110° F). Do not use the scrubbing functions in areas where the ambient temperature is less than freezing 0 °C (32 °F).

DRIVE SELECT SELECTOR

The knob on the control panel (**Fig.2**) can be used to select one of the following working modes:

	Transfer: movement of the machine without working.
	Drying: using the squeegee only.
	Scrubbing with Drying: using both the brushes and the squeegee.
	Scrubbing only : using only the brushes in the scrubbing brush head.

i **N.B.:** The working mode is selected when the corresponding indicator light is illuminated.

! **ATTENTION:** If you want to pass from a working mode with floor washing (washing only or washing with drying) to the transfer mode, always remember to select the vacuum mode for the time needed to collect the detergent solution on the ground.

HOURLY METER (ESSENTIAL VERSIONS)

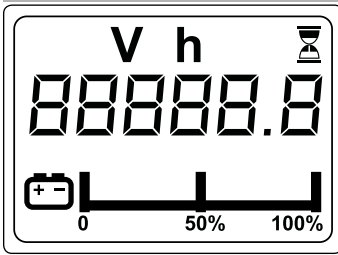

The command display is located on the control panel, and the screen that appears after the start-up screen displays the machine's total usage time. The digits that precede the "." identify hours, while the number after it indicates hour decimals (an hour decimal corresponds to six minutes). When the "hour glass" symbol is flashing, it indicates that the hour meter is counting the appliance operating time.

HOURLY METER (BRIGHT VERSIONS)

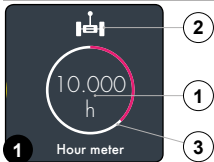

There is a box in the lower right-hand area of the command display work screen that allows you to see the partial time for which the machine has been used (1). The digits that precede the "." They refer to the hours, whereas the digits that follow refer to the minutes. The symbol (2) identifies which actuator is associated with the hour count; on pressing this symbol (2), a pop-up window will appear, allowing you to select which partial hour meter to view. You can choose from:

	Main switch.
	Traction motor.
	Brush motor.
	Suction motor.

i **N.B.:** The symbol (3) expresses the partial working hours as a percentage, with respect to the total working hours of the machine.

BATTERY CHARGE LEVEL INDICATOR (ESSENTIAL VERSIONS)

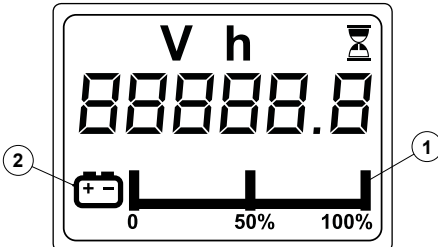

The control panel is equipped with a command display. The graphic symbol that identifies the charge level of batteries appears at the bottom of the command display.

The indicator consists of charge level symbols (1). When the minimum remaining charge is reached, the graphic symbol (1) will start to blink, and will turn off after a few seconds, after which the symbol (2) will start to blink. Under these conditions, the machine must be brought to the battery charging area.

i **N.B.:** A few seconds after the battery charge reaches the critical level (1), the brush gear motors will shut off automatically. With the remaining charge, it is possible to complete the drying process before starting the recharging process.

i **N.B.:** A few seconds after the battery charge level reaches the discharge level (1), the suction motor will shut off automatically.

BATTERY CHARGE LEVEL INDICATOR (BRIGHT VERSIONS)

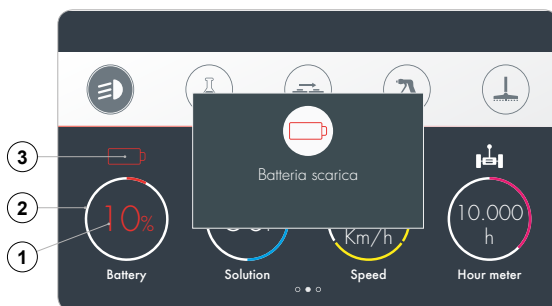

The graphic symbol that shows the charge level of the batteries appears on the command display work screen. The symbol is divided into three coloured sectors:

1. Numerical value (1): The number displayed (0+100) indicates the percentage charge remaining in the batteries.

i **N.B.:** As soon as the battery charge level reaches 20%, the numerical value changes from white to red.

2. Circular symbol (2): the circle (divided into ten segments) indicates the percentage of charge remaining in the batteries.

i **N.B.:** Each segment corresponds with 10% of the total battery charge. As soon as the battery charge level reaches 20%, the outside of the circle changes from green to red.

3. Battery silhouette symbol (3): the image depicting the battery (divided into five segments) indicates the percentage of charge remaining in the batteries.

i **N.B.:** Each segment corresponds with 20% of the total battery charge. As soon as the battery charge level reaches 20%, the outside of the symbol changes from white to red and begins to flash.

⚠ ATTENTION: As soon as the battery charge level reaches 20%, the brush head motors stop, while the suction motor keeps running for a short time. With the remaining charge, it is still possible to move the machine to the location designated for recharging the batteries.

i N.B. : As soon as the battery charge level reaches 20% , a pop-up window appears in the centre of the display advising that the battery charge level has reached critical level.

SELECTING THE OPERATING DIRECTION

The machine has a lever for selecting the travel direction (1) under the steering wheel (Fig.1).

i N.B.: To select the forward gear you need to first shift the lever up and then in the direction indicated by the arrow (Fig.2).

i N.B. : To go from forward to neutral, first move the lever in the direction indicated by the arrow (Fig.3).

i ATTENTION: To select the reverse gear, you need to first shift the lever up and then in the direction indicated by the arrow (Fig.4). With reverse gear engaged if you press the drive pedal a buzzer will sound and the white rear lights come on.

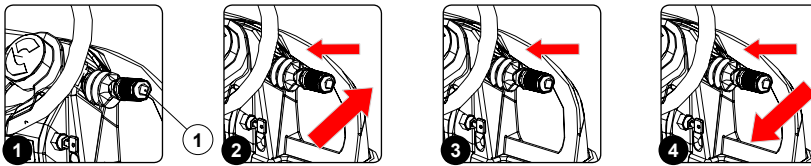

⚠ CAUTION: reverse speed is lower than forward speed, to comply with current health and safety standards.

i N.B.: In order to disengage the reverse gear, disengage the lever (1) underneath the steering wheel (Fig. 1).

i N.B. : Once the lever (1) has been engaged in the reverse position, the acoustic signalling device will be activated in order to signal that the machine's reverse gear has been engaged.

i N.B. : If the reverse gear is engaged with the squeegee in its working position, once the drive pedal is pressed, the machine will begin to move in reverse and the squeegee body will be raised into its resting position.

i N.B. : If the reverse gear is engaged with the brush head body in its working position, once the drive pedal is pressed, the machine will begin to move in reverse and the brush head will remain in its working position, but the solenoid valve will stop dispensing detergent solution to the brushes.

i N.B. : if you reverse with the video camera accessory (optional), the image is shown full screen.

ADJUSTING THE OPERATING SPEED

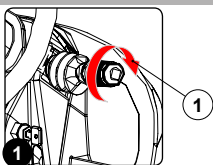

To adjust the operating speed, use the knob (1) on the gear lever (Fig.1).

i N.B.: It is possible to choose from three forward speeds; on the command display, the speed selected can be viewed through the circular symbol (2) located in the lower part of the screen (Fig.2). The symbol is divided into three sections, each of which corresponds to one of the speeds.

i N.B. : The current speed (3) of the machine is displayed inside the symbol (2), expressed in kilometres per hour (Fig.2).

⚠ CAUTION: adjust the forward speed to suit the adhesion conditions.

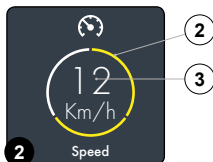

BUZZER

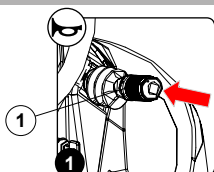

The machine is equipped with a buzzer. if you need to sound a warning, just press the button (1) on the gear lever (Fig.1).

ADJUSTING THE FLOW OF DETERGENT SOLUTION (ESSENTIAL VERSIONS)

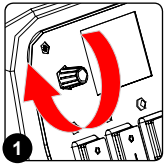

If it becomes necessary to adjust the delivery flow of detergent solution to the brushes while working, simply turn the knob on the control panel (Fig.1).

i **NB:** Turning the knob clockwise will increase the flow of detergent solution into the machine's water system, while turning it the other direction will reduce the quantity of detergent solution present in the machine's water system.

i **NB:** Turning the knob fully in an anticlockwise direction will stop the flow of detergent solution into the machine's water system.

ADJUSTING THE WORKING PARAMETERS (BRIGHT VERSIONS IN MANUAL MODE)

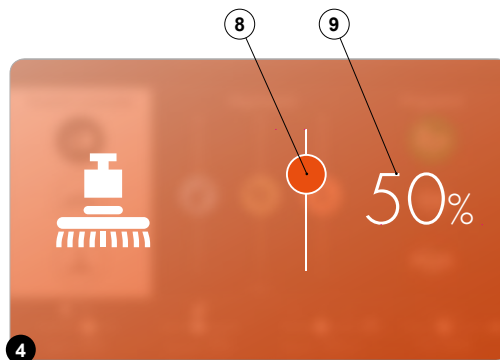
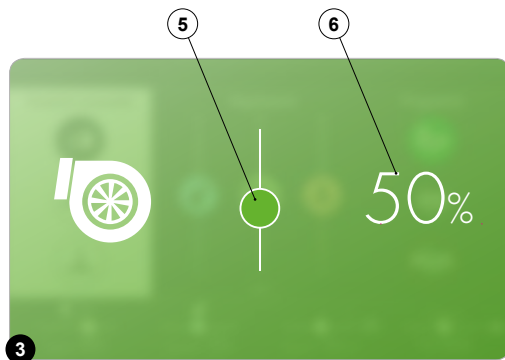
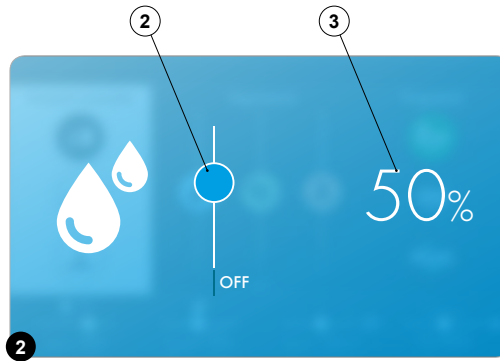
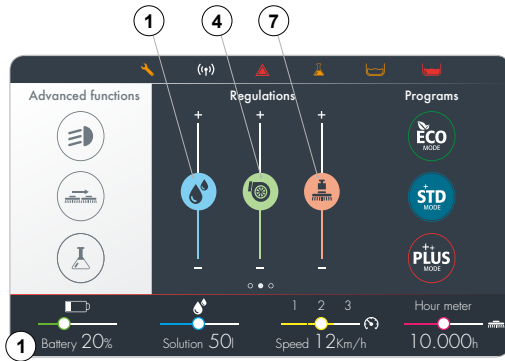

If it becomes necessary to adjust the delivery flow of detergent solution to the brushes while working, simply press the symbol (1) on the command display (Fig.1).

i **N.B.:** Pressing the symbol (1) will activate the detergent solution flow adjustment screen (Fig.2).

i **N.B. :** Moving the symbol (2) upwards on the adjustment screen will increase the delivery flow of detergent solution on the brushes (Fig.2).

i **N.B. :** Moving the symbol (2) downwards on the adjustment screen will decrease the delivery flow of detergent solution to the brushes (Fig.2).

i **N.B. :** Once the minimum value has been reached, moving further downwards and switching the symbol (2) to OFF will stop the delivery of detergent solution to the brushes.

i **N.B. :** The numerical value (3) indicates the percentage of flow delivered, with respect to the maximum flow rate of the pump in the machine's water system (Fig.2).

i **N.B. :** the amount of detergent solution should be selected on the basis of the type of floor and the amount and type of dirt to be removed.

If it becomes necessary to adjust the performance of the suction motor while working, simply press the symbol (4) on the command display (Fig.1).

i **N.B. :** Pressing the symbol (4) will activate the suction motor performance adjustment screen (Fig.3).

i **N.B. :** Moving the symbol (5) upwards on the adjustment screen will increase the performance of the suction motor (Fig.3).

i **N.B. :** Moving the symbol (5) downwards on the adjustment screen will decrease the performance of the suction motor (Fig.3).

i **N.B. :** The numerical value (6) indicates the percentage of performance of the suction motor, with respect to the maximum rpm of the motor during the work phase (Fig.3).

If it becomes necessary to adjust the weight exerted on the scrubbing brush head while working, simply press the symbol (7) on the command display (Fig.1).

i **N.B. :** Pressing the symbol (7) will activate the weight exerted on the scrubbing brush head adjustment screen (Fig.4).

i **N.B. :** Moving the symbol (8) upwards on the adjustment screen will increase the weight exerted on the scrubbing brush head (Fig.4).

i **N.B. :** Moving the symbol (8) downwards on the adjustment screen will decrease the weight exerted on the scrubbing brush head (Fig.4).

i **N.B. :** The numerical value (9) indicates the percentage of weight exerted on the brush head, with respect to the maximum weight that can be exerted during the working phase (Fig.4).



ATTENTION: To prevent manual adjustment of the working parameters, deactivate the "MANUAL MODE" function; refer to the dedicated paragraph in the programming booklet provided with the machine.

WORKING HEADLIGHTS FUNCTION (ESSENTIAL VERSIONS)

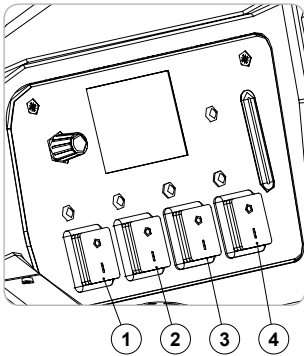

The machine is equipped with front and rear working lights. To activate them, move the switch (1) on the control panel to the "I" position.

i **N.B.:** If the function is active, the corresponding green LED will be illuminated.

i **N.B.:** the sidelights come on when the machine is started.

i **N.B.:** If you wish to switch off the working lights, move the switch (1) to position "0".

EXTRA PRESSURE FUNCTION (ESSENTIAL VERSIONS)

If it becomes necessary to activate the "EXTRA PRESSURE ON BRUSH HEAD BODY" function while working, move the switch (2) to position "I".

i **N.B.:** If you wish to deactivate the function, move the switch (2) to position "0".

BRUSH HEAD BODY LATERAL MOVEMENT FUNCTION (ESSENTIAL VERSIONS)

If it becomes necessary to activate the "BRUSH HEAD BODY LATERAL MOVEMENT" function while working, move the switch (3) to position "I".

i **N.B.:** If you wish to deactivate the function, move the switch (3) to position "0".

AUTOMATIC DETERGENT DOSING FUNCTION (ESSENTIAL VERSIONS WITH CDS)

If it becomes necessary to activate the "AUTOMATIC DETERGENT DOSING" function while working, move the switch (4) to position "I".

i **N.B.:** If you wish to deactivate the function, move the switch (4) to position "0".

WORKING HEADLIGHTS FUNCTION (BRIGHT VERSIONS)

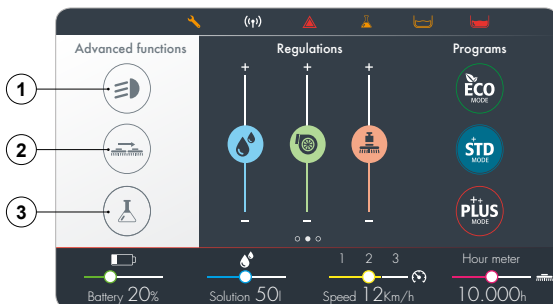

The machine is equipped with front and rear working headlights; to switch these on, press the button (1) on the work screen.

i **N.B.:** If the button is white, this means that the function is not active. If the button is grey, this means that the function is active.

i **NOTE:** the sidelights come on when the machine is started.

i **N.B.:** If you wish to switch off the working headlights, press the button (1).

BRUSH HEAD BODY LATERAL MOVEMENT FUNCTION (BRIGHT VERSIONS)

If it becomes necessary to activate the "BRUSH HEAD BODY LATERAL MOVEMENT" function while working, press the brush head body movement button (2) on the work screen.

- i** **N.B.:** The scrubbing brush head will only begin to move towards the outside of the machine when the drive pedal is pressed.
- i** **N.B.:** If you wish to bring the scrubbing brush head back inside the machine, press the button (2).
- i** **N.B.:** when the drive pedal is released all the brush head motors stop with the respective delays. After the "Reset Delay" time, the brush head will be moved back inside the machine and then moved to the idle position (raised off the floor). Even if the scrubbing brush head is in the rest position, the lateral movement function is still active; indeed, when the drive pedal is operated, the brush head will be brought back into the working position (in contact with the floor).

AUTOMATIC DETERGENT DOSING SYSTEM FUNCTION (BRIGHT VERSIONS)

If it becomes necessary to activate the "AUTOMATIC DETERGENT DOSING SYSTEM" function while working, press the detergent pump activation button (3) on the work screen.

- i** **N.B.:** The CDS system activates when the electric pump in the machine's water system is activated.
- i** **N.B.:** if you want to deactivate the CDS system, press the button (3) again.
- i** **N.B.:** Before starting any work, remember to start the CDS system.

COURTESY LIGHTS (OPTIONAL)

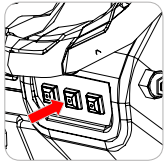

The machine can be equipped with courtesy lights to increase visibility of the parts which may need to be checked by the operator. To activate these lights, simply press the central switch located on the steering column.

REAR VIDEO CAMERA (BRIGHT VERSION)

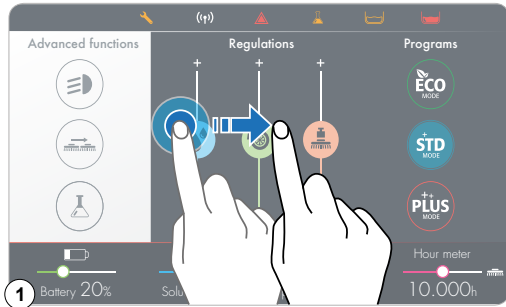

Upon request, the machine can be fitted with a rear video camera, which allows you to view the condition of the floor where you have just passed over, and it also helps when reversing, allowing you to identify any obstacles. If it becomes necessary to view the floor that has just been washed when working, touch your finger on the screen at any point and move from left to right (**Fig.01**); as soon as you do so, the image from the connected video camera will be displayed, and on the right-hand side of the display, the base parameters of the machine can be viewed.

- i** **N.B.:** The machine uses a lever system for selecting the direction of travel; on engaging reverse gear (see "[SELECTING THE OPERATING DIRECTION](#)" for how to do this), the command display will show the image from the connected video camera, and on the right-hand side of the display, the base parameters of the machine can be viewed (**Fig.2**).

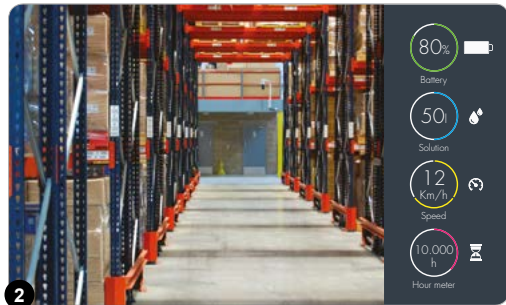

EMERGENCY STOP BUTTON

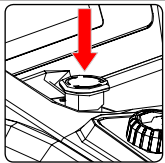

If any serious problems are encountered during the work operations, press the emergency stop button on the electrical system carter.

- !** **CAUTION:** this control stops the active functions on the machine and immediately halts traction.
- i** **N.B.:** To recommence work having stopped and once the problem has been resolved, switch off the machine and turn the knob (1) in the direction of the arrows indicated on it.

ANTI-COLLISION SYSTEM (BRIGHT VERSIONS)

On request, the machine can be equipped with an anti-collision system.

CAUTION: Anti-collision systems reveal the presence of obstacles or other vehicles approaching.

The machine is equipped with an “ultrasound sensor” fitted on the rear, which continuously emits impulses. These bounce off any obstacles they encounter, and then come back to the sensor. A special software uses the speed of the vehicle and the distance from the obstacle to judge whether this constitutes a danger; if this is the case, it activates an audible alarm which varies in accordance with the distance from the object detected.



N.B.: If the machine is equipped with the rear video camera, on engaging reverse gear, the command display will show the image from the connected video camera, and on the right-hand side of the display, a stylised outline of the machine will be shown.

N.B.: On the lower part of this outline, three concentric arcs (1) will be visible, representing the three zones of proximity to the machine. Each arc represents a step of around circa 50cm (19.69in).

N.B.: The orange arc indicates that the obstacle is within the machine's immediate working area. The grey arc indicates that there is no obstacle within the machine's immediate working area.

N.B.: If the anti-collision function is active (with the parameter “ON”), pressing the button (2) will momentarily activate the “SLOWDOWN” function; this function ensures that once a certain (parametrised) distance is reached, the machine will begin to automatically slow down.

N.B.: If the anti-collision function is active (with the “SLOWDOWN” parameter), pressing the button (2) will momentarily deactivate the “SLOWDOWN” function; the machine will nonetheless emit a warning sound if it approaches an obstacle.

N.B.: If the button (2) is orange, this means that the “SLOWDOWN” function is active; if the button (2) is grey, this means that the “SLOWDOWN” function is not active.

ALARM SCREEN

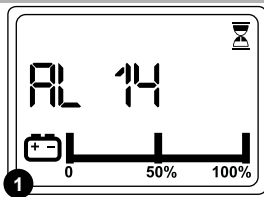

In Essential versions, when there is an error, the text AL is shown on the command display followed by a number (Fig.1); this stays visible until the error is resolved.

When an error occurs, proceed as follows:

1. Stop the machine immediately.
2. If the error persists, switch off the machine and wait at least ten seconds before switching it back on.
3. If the error persists contact the nearest service centre.

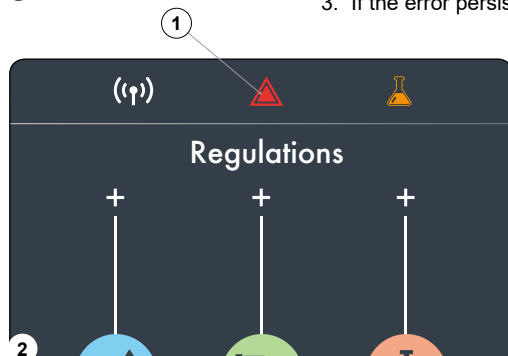

In Bright versions, when an error occurs, the symbol (1) is displayed in the information field. This remains visible until the error has been resolved (Fig.2). The “ERROR” pop-up will also be superimposed on the work screen (Fig.3), which describes the alarm number (2), the group to which it belongs and a brief description (3).

The alarms can be divided into the following groups:

- **Lock:** if an error pop-up from this category appears on the command display, to go back to the previous screen, simply press any area of the touch screen. This does not reset the error, which will remain active; indeed, the symbol (1) will still be visible in the information field. The error can only be reset by switching off and restarting the machine.
- **Auto reset:** if an error pop-up from this category appears on the command display, to go back to the previous screen, simply resolve the issue that generated the error (for example, if the drive pedal remains pressed while the machine is being switched on, the command display will show the “ALARM: 104 DRIVE PEDAL PRESSED” screen - in this instance, just release the drive pedal to make the alarm screen disappear).

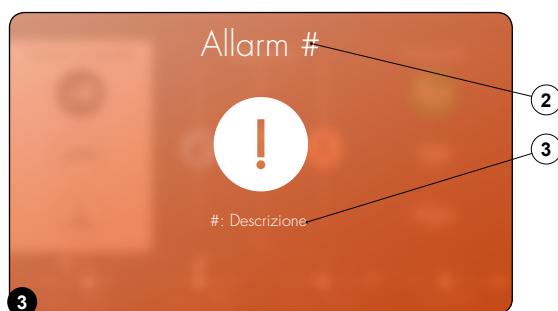

N.B.: In the work screen, pressing the symbol (1), if visible, will recall the most recent “ERROR” pop-up displayed.

BRAKING CONTROL

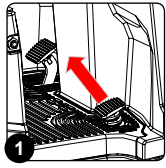

The machine has an encoder to help braking and also a mechanical brake.

- If the machine is moving and the accelerator pedal (**Fig.1**) is released, the machine brakes, decelerating gently until it stops the encoder. Only when the encoder has stopped is the electric brake engaged.
- If the machine is moving and the brake pedal (**Fig.2**) is pressed, the machine brakes according to the braking force of the mechanical system. Only when the encoder has stopped is the electric brake engaged.

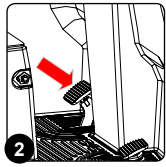

CAUTION: The electro-brake on the machine only serves as a parking brake.

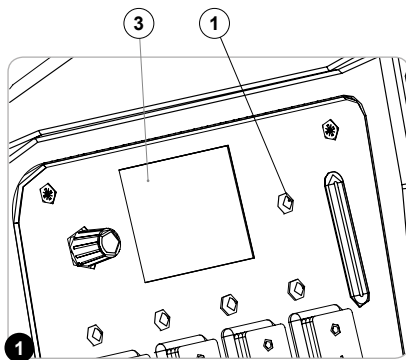

SOLUTION TANK CAPACITY LOW

The machine is equipped with an electronic device (float) located inside the solution tank, which, when the solution tank is empty, activates the solution tank float indicator light (1) on the control panel (**Fig.1**) for Essential versions, and the solution tank float indicator light (2) on the command display (**Fig.2**) for Bright versions.

If this is the case, proceed as follows:

1. Using the "DRIVE SELECTION" selector knob on the control panel, select the "TRANSPORT" working program (A). The brush motors and solenoid valve will stop working, and after a few seconds the brush head bodies will lift up from the floor. The squeegee will remain in contact with the floor for a few seconds, to allow the drying to finish, after which it will lift up off the floor. A few seconds after the squeegee has reached its idle position, the suction motors will stop working; this is to allow all the liquid in the vacuum tube to be vacuumed off.
2. Bring the machine to the maintenance area and fill the solution tank with detergent solution (refer to the section titled "[FILLING THE SOLUTION TANK](#)").

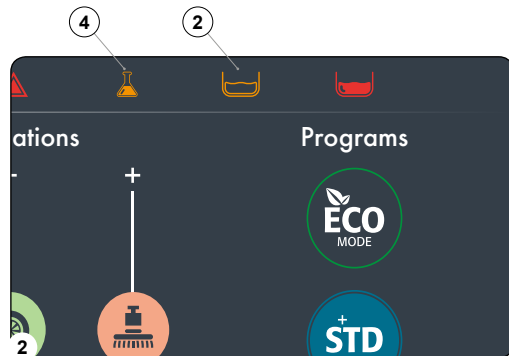

ATTENTION: When filling the solution tank, it is good practice to drain the recovery tank using the special drainage tube.

DETERGENT TANK CAPACITY LOW

The machine is equipped with an electronic device (float) located inside the detergent tank, which, when the detergent tank is empty, activates an alarm signal on the control display (3) (**Fig.1**) for Essential versions, and switches on the orange detergent tank float indicator light (4) on the command display (**Fig.2**) for Bright versions.

If this is the case, proceed as follows:

1. Using the "DRIVE SELECTION" selector knob on the control panel, select the "TRANSPORT" working program (A). The brush motors and solenoid valve will stop working, and after a few seconds the brush head bodies will lift up from the floor. The squeegee will remain in contact with the floor for a few seconds, to allow the drying to finish, after which it will lift up off the floor. A few seconds after the squeegee has reached its idle position, the suction motors will stop working; this is to allow all the liquid in the vacuum tube to be vacuumed off.
2. Bring the machine to the maintenance area and fill the detergent tank with the chemical product used (read the paragraph entitled "[FILLING THE DETERGENT TANK, VERSION WITH CDS](#)").

LIQUID VACUUM WAND KIT (OPTIONAL)

Upon request, the machine can be fitted with the LIQUID VACUUM WAND system that vacuums up the detergent solution more accurately. To start it, proceed as follows.

1. Using the knob (1) of the DS selector (**Fig.1**), select the "transfer" program.
2. Open the storage compartment flap (2) (**Fig.2**), positioned on the left-hand side of the operator seat, and remove all components of the liquid vacuum wand kit.
3. Assemble the steel extension tube (**Fig.3**).
4. Connect the vacuum tube (4) to the extension tube (3) (**Fig.4**).
5. Insert the vacuum brush (5) in the extension tube (3) (**Fig.5**).
6. Remove the vacuum tube (6) from the sleeve (7) in the squeegee body (**Fig.6**).

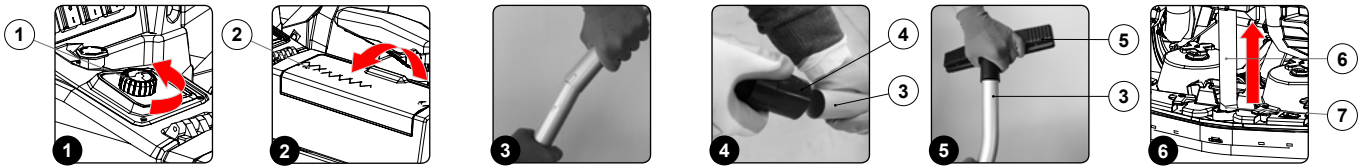

7. Connect the liquid vacuum wand kit vacuum tube (4) to the squeegee vacuum tube (5) (Fig.7).
8. For Essential versions, activate the liquid vacuum wand kit by pressing the switch (8) on the steering column (Fig.8)
9. For Bright versions, activate the liquid vacuum wand kit by pressing the button (9) on the command display (Fig.9).

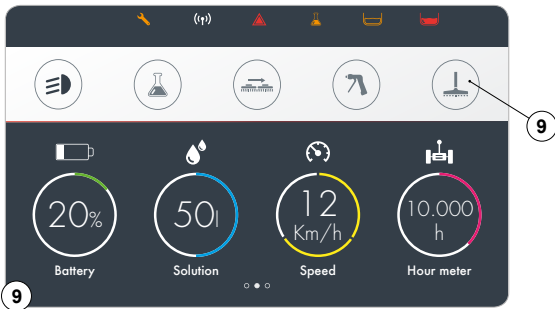
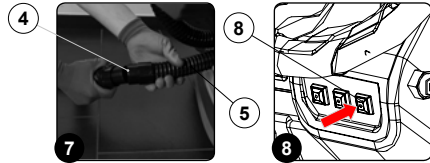

- i** **N.B.:** As soon as the switch (8) or button (9) is pressed, the suction motor will be activated, and the drying operation can be performed.
- i** **N.B.:** If the liquid vacuum wand kit activation/deactivation button (9) is white, this means that the function is not active (Fig.9). If the liquid vacuum wand kit activation/deactivation button (9) is grey, this means that the function is active (Fig.9).
- !** **WARNING:** Never pick up solid matter such as dust, cigarette stubs, paper, etc.
- !** **CAUTION:** Never collect gases, explosive/inflammable liquids or powders, nor acids and solvents! These include gasoline, paint thinners and fuel oil (which, when mixed with the vacuum air, can form explosive vapours or mixtures), and also non-diluted acids and solvents, acetones, aluminium and magnesium powders. These substances may also corrode the materials used to construct the machine.

! **CAUTION:** If the machine is used in dangerous areas (e.g. petrol stations), the relative safety standards must be observed. It is forbidden to use the machine in environments with a potentially explosive atmosphere.

12. When the work is finished, remove the kit and place it in the storage compartment.

TANK CLEANING KIT (OPTIONAL)

On request, the machine can be equipped with the SPRAY GUN system; to activate this, proceed as follows.

! **CAUTION:** it is recommended to wear the appropriate PPE (Personal Protective Equipment) for the work to be carried out.

1. Using the knob (1) of the DS selector (Fig.1), select the "transfer" program.
2. Release the tank cleaning accessory (2) (at the back of the machine) from the retainers (Fig.2).
3. For Essential versions, activate the optional tank cleaning kit by pressing the button (3) on the steering column (Fig.3).
4. For Bright versions, activate the optional tank cleaning kit by pressing the button (4) on the command display (Fig.4).

i **N.B.:** If the tank cleaning kit activation/deactivation button (4) is white, this means that the function is not active. If the tank cleaning kit activation/deactivation button (4) is grey, this means that the function is active.

i **N.B.:** On Bright versions, before activating the optional tank cleaning kit, check the level indicator (5) on the command display to see how much solution there is in the solution tank (Fig.4).

5. Activate the solution jet by pressing the lever in the tank cleaning accessory. Take care to direct the solution jet in the desired direction.

i **N.B.:** To adjust the solution jet from the tank cleaning accessory, turn the knob (6) on the accessory itself (Fig.5).

i **N.B.:** To adjust the intensity of the solution jet from the tank cleaning accessory, turn the knob (7) on the accessory itself (Fig.6).

i **N.B.:** To stop the solution jet, use the lever (8) on the tank cleaning accessory (Fig.7).

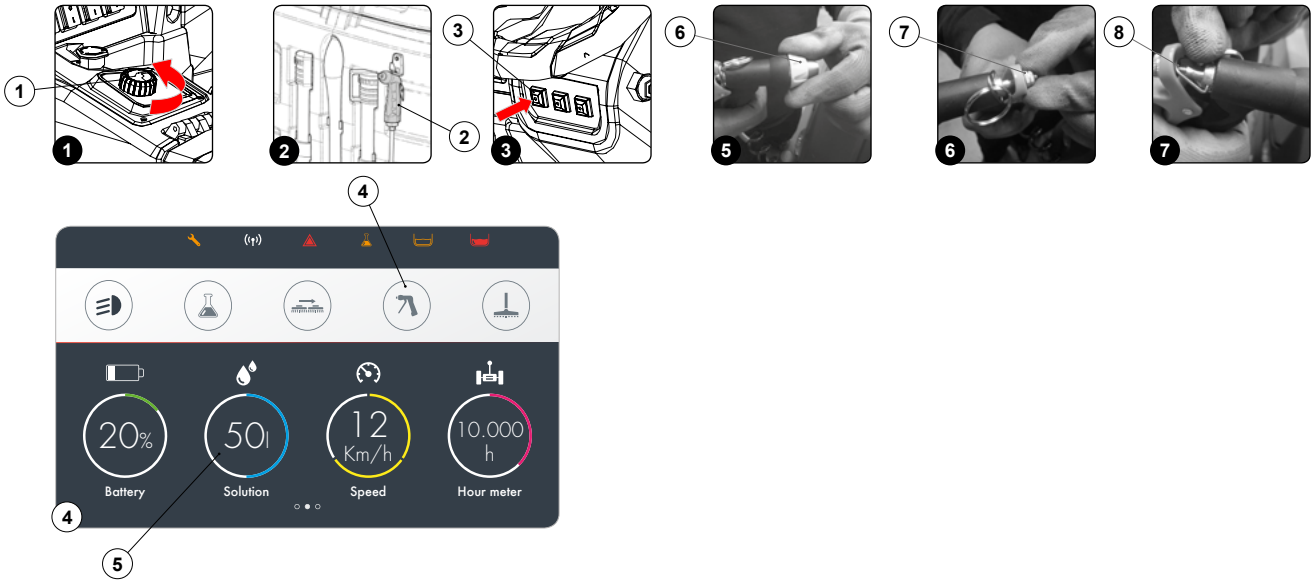

PERIODIC MAINTENANCE FUNCTION

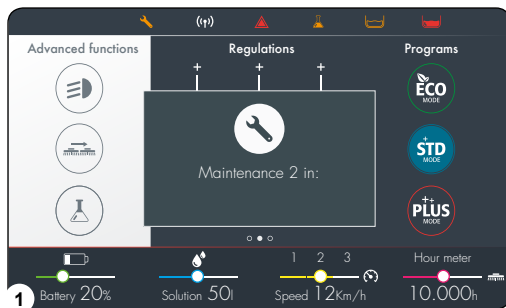

For the Bright version, the “PERIODIC MAINTENANCE FUNCTION” can be activated; this function enables maintenance to be set cyclically and warns the operator before the maintenance period set, as well as once this is overdue. To activate the function, call your local retailer.

i **N.B.:** Routine maintenance of the machine is a necessary activity, to ensure that it is always ready to work optimally. The most important periodic checks are essential for assessing the conditions of the machine and in order to ensure all the equipment is running properly, to guarantee the best possible performance. These checks must not be missed, in order to avoid sanctions and to prevent the loss of the right to the factory warranty. Generally speaking, correct maintenance enables the productivity levels of the machine to remain high, along with its efficiency and safety when working, and is beneficial in that it increases the life cycle of the machine itself.

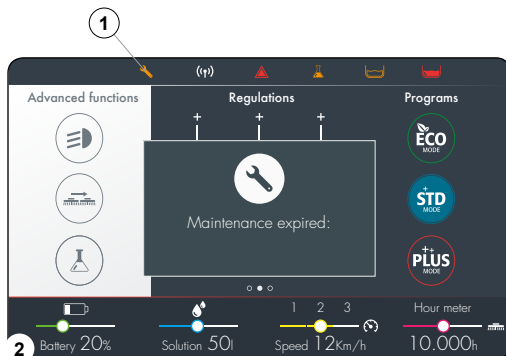

i **N.B.:** Shortly before maintenance is due, a pop-up window will appear on the machine on start-up, advising that maintenance is due (Fig.1).

i **N.B.:** After the maintenance period set has passed, a pop-up window will appear on the machine on start-up, advising that maintenance is overdue (Fig.2). In addition, the symbol (1) will appear on the upper tool bar of the display to indicate that the operator needs to contact their local retailer to perform scheduled maintenance.

i **N.B.:** The symbol (1) can only be reset by the local retailer after maintenance has been carried out.

AT THE END OF THE WORK

At the end of the work, and before carrying out any type of maintenance, perform the following operations:

- Using the "DRIVE SELECTION" selector knob on the control panel, select the "TRANSPORT" working program (A). The brush motors and solenoid valve will stop working, and after a few seconds the brush head bodies will lift up from the floor. The squeegee will remain in contact with the floor for a few seconds, to allow the drying to finish, after which it will lift up off the floor. A few seconds after the squeegee has reached its idle position, the suction motors will stop working; this is to allow all the liquid in the vacuum tube to be vacuumed off.
- Bring the machine to the designated place for draining off the dirty water, and empty the recovery tank (see "[EMPTYING THE RECOVERY TANK](#)").
- Carry out all the procedures listed in the paragraph "[RECOMMENDED PERIODIC MAINTENANCE](#)" indicated in the section "DAILY; BEFORE A LONG PERIOD OF INACTIVITY".
- Once the maintenance operations are complete, take the machine to the designated storage location.

⚠ ATTENTION: Park the machine in an enclosed place, on a flat surface, and at a safe distance from any objects that could either damage it or be damaged due to contact with the machine itself.

- Make sure the machine is in a safe condition, see chapter "[MACHINE SAFETY MEASURES](#)".

RECOMMENDED MAINTENANCE OPERATIONS

INTERVAL	MACHINE COMPONENTS	PROCEDURE
DAILY; BEFORE A LONG PERIOD OF INACTIVITY	Squeegee	Clean the vacuum chamber; the squeegee rubber blades; the vacuum nozzle (see “CLEANING THE SQUEEGEE BODY”).
	Scrubbing brush head body side splash guard rubber blades	Clean the scrubbing brush head body side splash guard rubber blades (see “CLEANING THE SCRUBBING BRUSH HEAD SIDE SPLASH GUARD RUBBER BLADES”).
	Scrubbing brush head body brushes	Clean the brushes on the scrubbing brush head body (see “CLEANING THE SCRUBBING BRUSH HEAD BODY BRUSHES”).
	Recovery tank	At the end of every working day, empty the recovery tank (see “EMPTYING THE RECOVERY TANK”).
		At the end of every working day, after having emptied the recovery tank, clean the vacuum system filters (see “CLEANING THE RECOVERY TANK FILTERS”).
Solution tank	At the end of every working day, empty the solution tank (see “EMPTYING THE SOLUTION TANK”).	
WEEKLY	Machine water system	Clean the filter in the machine's water system (see “CLEANING THE WATER SYSTEM FILTER”).
	Squeegee rubber blades	Check that the rubber blades on the squeegee body are intact and inspect for wear; if necessary, replace these (see “REPLACING THE SQUEEGEE BODY RUBBER BLADES”).
	Scrubbing brush head body side splash guard rubber blades	Check that the rubber blades on the side splash guards of the scrubbing brush head body are intact and inspect for wear; if necessary, replace these (see “REPLACING THE SCRUBBING BRUSH HEAD BODY SPLASH GUARDS”).
	Scrubbing brush head body brushes	Check that the brushes on the scrubbing brush head body are intact and inspect for wear; if necessary, replace these (see “REPLACING THE SCRUBBING BRUSH HEAD BODY BRUSHES”).
MONTHLY	Squeegee rubber blade levelling	Check that the rubber blades on the squeegee body are level and if necessary, adjust these (see “ADJUSTING THE SQUEEGEE BODY RUBBER BLADES”).
	Levelling the scrubbing brush head body splash guard rubber blades	Check that the rubber blades on the side splash guards of the scrubbing brush head body are level and if necessary, adjust these (see “ADJUSTING THE SCRUBBING BRUSH HEAD BODY SIDE SPLASH GUARDS”).

Before performing any routine or extraordinary maintenance operation, proceed as follows:

1. Take the machine to the maintenance area.



N.B.: the place designated for this operation must comply with current environmental protection regulations.

2. Make sure the machine has been secured (see the chapter entitled [“SECURING THE MACHINE”](#)).



CAUTION: it is recommended to wear the appropriate PPE (Personal Protective Equipment) for the work to be carried out.

CLEANING THE SQUEEGEE BODY

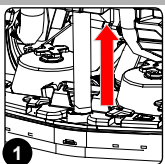

The careful cleaning of the whole vacuum unit ensures better drying and cleaning of the floor as well as a longer suction motor life. To clean the squeegee body, proceed as follows:

1. Extract the vacuum tube from the vacuum nozzle on the squeegee body (**Fig.1**).
2. Completely unscrew the knobs on the squeegee body pre-assembly (**Fig.2**).
3. Remove the squeegee body from the slits in the squeegee connector.
4. Thoroughly clean the vacuum chamber of the squeegee body, first with a jet of water and then with a damp cloth.
5. Thoroughly clean the rear rubber blade of the squeegee body, first with a jet of water and then with a damp cloth.
6. Thoroughly clean the front rubber blade of the squeegee body, first with a jet of water and then with a damp cloth.
7. Thoroughly clean the vacuum nozzle with a jet of water, and then with a damp cloth.
8. If you wish to use the tank cleaning kit to clean the squeegee body, see [“TANK CLEANING KIT \(OPTIONAL\)”](#).
9. Proceed in reverse order to reassemble all the parts.

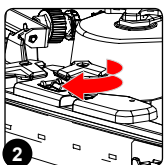

i N.B.: Check the wear of the rear rubber blade (4) on the squeegee body; if the edge of the rubber in contact with the floor is worn, replace it. Refer to [“REPLACING THE SQUEEGEE BODY RUBBER BLADES”](#).

i N.B.: Check the wear of the front rubber blade (5) on the squeegee body; if the edge of the rubber in contact with the floor is worn, replace it. Refer to [“REPLACING THE SQUEEGEE BODY RUBBER BLADES”](#).

CLEANING THE SCRUBBING BRUSH HEAD LATERAL SPLASH GUARD RUBBER BLADES

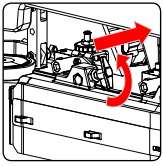

Careful cleaning of the side splash guard rubber blades of the scrubbing brush head guarantees better cleaning of the floor. To clean the side splash guard rubber blades, proceed as follows:

1. Go to the left hand side of the machine, and with the brush head raised up from the floor, remove the side splash guard casing from the brush head (**Fig.2**).

i **N.B.:** Before removing the splash guard casing, turn the fixing anchors (1) on the brush head body to the maintenance position (**Fig.1**).

2. Use a jet of water and then a damp cloth to thoroughly clean the side splash guard rubber blade (2) (**Fig.3**)
3. Reassemble all parts and repeat the operations described for the right side casing.

CLEANING THE SCRUBBING BRUSH HEAD BODY BRUSHES

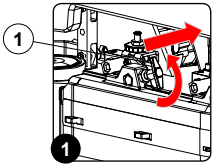

Careful cleaning of the brush guarantees better cleaning of the floor as well as a longer lifespan of the gear motor present in the brush head body. To clean the brushes, proceed as follows

1. Go to the left hand side of the machine, and with the brush head raised up from the floor, remove the side splash guard casing from the brush head.

i **N.B.:** Before removing the splash guard casing, turn the fixing anchors (1) on the brush head body to the maintenance position (**Fig.1**).

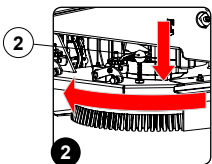

2. Press the brush locking pin (2) (**Fig.2**).
3. Keeping the pin (2) pressed, turn the brush clockwise until it is secured in place (**Fig.2**).
4. Turn until the button is pushed towards the outside of the coupling spring and is locked into place.
5. Clean the brush under a stream of running water to remove any impurities from its bristles. Check the wear status of the bristles and replace the brushes if they are excessively consumed (the bristle protrusion must not be less than 10mm; this distance is indicated on the brush by the yellow band). For replacing the brushes, refer to "[FITTING THE SCRUBBING BRUSH HEAD BRUSHES](#)".

6. After checking to make sure that the brush is clean, reassemble it and move on to the one on the right hand side.

i **N.B.:** it is advisable to invert the position of the right and left-hand brushes every day.

i **N.B.:** The image in **Fig.2** indicates the direction of rotation for uncoupling the left brush; the right brush must be turned in the opposite direction.

! **ATTENTION:** If the brushes are not new and have deformed bristles, it is better to reassemble them in the same position (the right-hand one on the right, and the left-hand one on the left), to prevent the different inclination of the bristles from producing an overload on the brush motor as well as excessive vibrations.

7. If you wish to use the tank cleaning kit to clean the brushes, see "[TANK CLEANING KIT \(OPTIONAL\)](#)".
8. Proceed in reverse order to reassemble all the parts.

DRAINING THE RECOVERY TANK

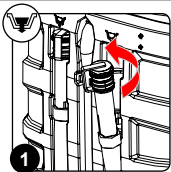

Proceed as follows to empty the recovery tank:

1. Remove the drainage hose of the recovery tank from the clamps; it is located at the rear of the machine (**Fig.1**).
2. Bend the end of the drainage tube in order to create a choke and prevent the content from coming out (**Fig. 2**), then position the tube on the discharge surface, unscrew the cap, and gradually release the tube.
3. Repeat the operations in reverse order to reassemble all the parts.

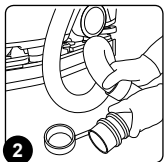

CLEANING THE RECOVERY TANK FILTERS

In order to clean the filters present inside the recovery tank, do the following:

1. Release the retainer hinges (1) on the side of the tank (**Fig.1**).
2. Rotate the recovery tank cover until the prop (2) is in the maintenance position (**Fig.2**).
3. Remove the dirty water basket/filter from the support (3) (**Fig.3**).
4. Remove the basket cover (4) from the basket/filter (3) (**Fig.4**).
5. Clean the basket/filter (3) and the basket cover (4) under a jet of running water.

i **N.B.:** use a spatula or brush to eliminate any dirt that is particularly difficult to remove.

6. Use a dry cloth to dry the basket/filter (3) and the basket cover (4) and place them back inside the recovery tank.
7. Remove the filter support (5), fully unscrew the locking wing nuts (6) (**Fig.5**).
8. Remove the suction motor filter (7) (**Fig.6**).
9. Clean the suction motor filter (7) with an air jet from a distance of more than 20cm.

i **N.B.:** If the dirt will not shift, use a vacuum cleaner.

i **N.B.:** Be sure to also clean the electro-mechanical float inside the tank.

10. If you wish to use the tank cleaning kit to clean the brushes, see "[TANK CLEANING KIT \(OPTIONAL\)](#)"

11. Repeat the operations in reverse order to reassemble all the parts.

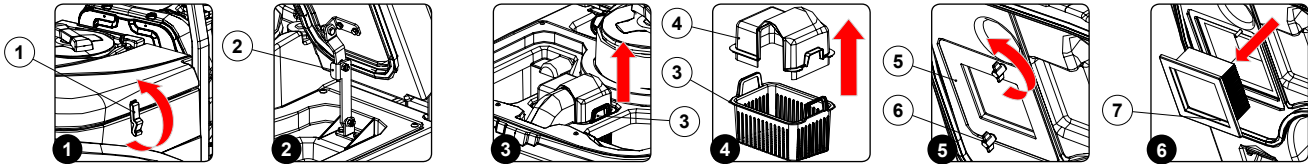

EMPTYING THE SOLUTION TANK

Proceed as follows to empty the recovery tank:

1. Remove the solution tank filler cap (**Fig.1**).
2. Remove the drainage hose of the solution tank from the clamps; it is located at the rear of the machine (**Fig.2**).
3. Bend the end of the drainage tube in order to create a choke and prevent the content from coming out (**Fig.3**), then position the tube on the discharge surface, unscrew the cap, and gradually release the tube.
4. Repeat the operations in reverse order to reassemble all the parts.

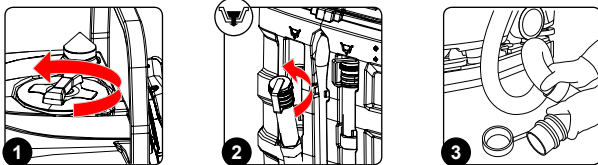

CLEANING THE WATER SYSTEM FILTER

In order to clean the water system's filter, do the following:

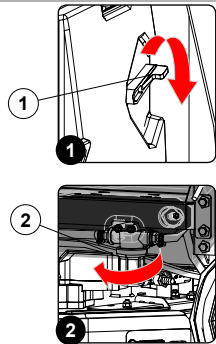

1. Close the tap's output flow, and shift the knob (1) on the left hand side of the steering column (**Fig. 1**) downward.
2. Unscrew the detergent solution filter cap (3) (**Fig.2**).
3. Remove the cartridge from the filter body and rinse under a jet of running water, and use a brush to eliminate any impurities, if necessary.
4. Once the filter cartridge is clean, repeat the operations in the reverse order to reassemble all the parts.

CLEANING THE VACUUM TUBE

Careful cleaning of the vacuum hose guarantees better cleaning of the floor as well as a longer suction motor life. Proceed as follows to clean the vacuum tube:

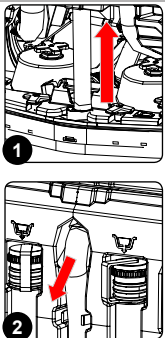

1. Extract the vacuum tube from the vacuum nozzle on the squeegee body (**Fig.1**).
2. Remove the vacuum tube via the hole on the back of the recovery tank (**Fig.2**).
3. The vacuum hose from the retainers present inside the recovery tank.
4. Rinse the inside of the vacuum tube with a jet of running water.
5. If you wish to use the tank cleaning kit to clean the vacuum tube, see "[TANK CLEANING KIT \(OPTIONAL\)](#)"
6. Repeat the operations in reverse order to reassemble all the parts.

EXTRAORDINARY MAINTENANCE WORK

Before performing any routine or extraordinary maintenance operation, proceed as follows:

1. Take the machine to the maintenance area.



N.B.: the place designated for this operation must comply with current environmental protection regulations.

2. Make sure the machine has been secured (see the chapter entitled "[SECURING THE MACHINE](#)").



CAUTION: it is recommended to wear the appropriate PPE (Personal Protective Equipment) for the work to be carried out.

REPLACING THE SQUEEGEE BODY RUBBER BLADES

Ensuring the integrity of the squeegee body's rubber blades guarantees better floor cleaning and drying results, as well as a longer service life for the suction motor. To replace the squeegee body rubber blades, proceed as follows:

1. Remove the vacuum tube (1) from the vacuum nozzle on the squeegee body (**Fig.1**).
2. Completely unscrew the knobs (2) in the squeegee body pre-assembly (**Fig.2**).
3. Remove the squeegee body from the slits in the squeegee connector.
4. Remove the rear rubber blade compression plate, and release the stopper (3) at the rear of the squeegee (**Fig. 3**).
5. Remove the rear rubber blade (4) from the squeegee body (**Fig. 4**).
6. Completely unscrew the knobs (5) in the squeegee body pre-assembly (**Fig.5**).
7. Remove the front rubber blade (6) from the squeegee's internal body (**Fig. 6**).

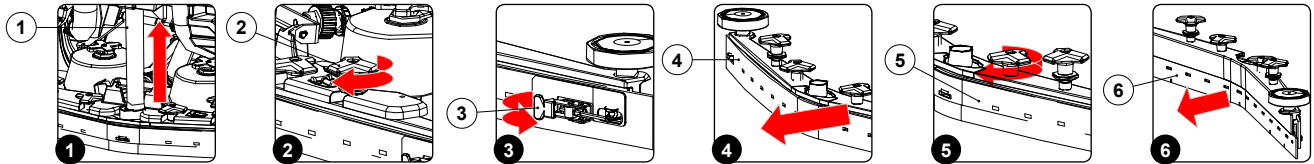

8. Repeat the operations in reverse order to reassemble all the parts.



NB: before using the machine, remember to adjust the squeegee body. Read "[ADJUSTING THE SQUEEGEE BODY RUBBER BLADES](#)".



NB: it is good practice to replace both squeegee blades, to ensure good results when drying the floor.

REPLACING THE SCRUBBING BRUSH HEAD BODY SPLASH GUARD

If the splash guard rubber blades of the brush head side casing are damaged they cannot work properly, namely they cannot convey the dirty detergent solution towards the squeegee, therefore the splash guard rubber blades need to be checked. To replace the brush head splash guards, proceed as follows:

1. Stand on the left side of the machine.
2. Remove the left splash guard body (1) and move the fixing anchors (2) on the brush head body into the maintenance position (**Fig.1**).
3. Remove the rear rubber blade compression plate (3), and release the stopper (4) on rubber blade compression plate (**Fig.2**).
4. Remove the splash guards (5) from the left splash guard body and replace it with a new one or else turn it around (**Fig.3**).

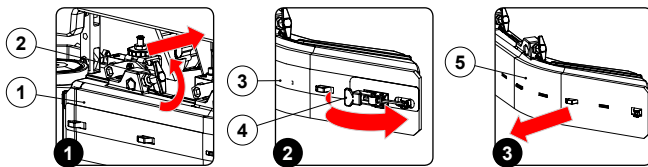

5. Repeat the operations in reverse order to reassemble all the parts.
6. Repeat the operations just carried out also for the right side casing as well.

REPLACING THE SCRUBBING BRUSH HEAD BODY BRUSHES

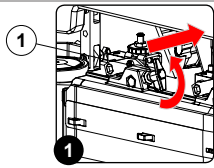

If the scrubbing brush head brushes are damaged they cannot work properly, or more specifically, they cannot remove the dirt from the floor; as such, the condition of these must be checked. To replace the scrubbing brush head body, proceed as follows:

1. Go to the left hand side of the machine, and with the brush head raised up from the floor, remove the side splash guard casing from the brush head.

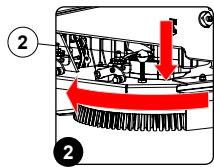

i **N.B.:** Before removing the splash guard casing, turn the fixing anchors (1) on the brush head body to the maintenance position (Fig.1).

2. Press the brush locking pin (2) (Fig.2).
3. Keeping the pin (2) pressed, turn the brush clockwise until it is secured in place (Fig.2).
4. Turn until the button is pushed towards the outside of the coupling spring and is locked into place.
5. Check the wear status of the bristles and replace the brushes if they are excessively consumed (the bristle protrusion must not be less than 10mm; this distance is indicated on the brush by the yellow band). For replacing the brushes, refer to "FITTING THE SCRUBBING BRUSH HEAD BRUSHES".

6. After checking to make sure that the brush is clean, reassemble it and move on to the one on the right hand side.

i **N.B.:** The image in Fig.2 indicates the direction of rotation for uncoupling the left brush; the right brush must be turned in the opposite direction.

7. Proceed in reverse order to reassemble all the parts.

ADJUSTMENT INTERVENTIONS

ADJUSTING THE SQUEEGEE BODY RUBBER BLADES

Careful adjustment of the squeegee body rubber blades guarantees better cleaning of the floor.

To adjust the squeegee body blades, proceed as follows:

1. Sit on the driver's seat.
2. Insert the key (1) in the main switch on the control panel. Set the main switch to "I" (Fig.1).
3. Using the knob (2) on the control panel (Fig.2), select the "SCRUBBING WITH DRYING" work program.
4. Press the drive pedal (3) (Fig. 3) to begin moving the machine.

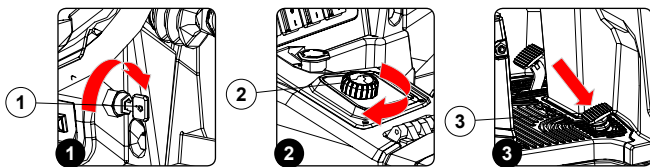

5. As soon as the brush head and the squeegee have reached their working positions, perform the procedure for securing the machine (see the chapter "MACHINE SAFETY MEASURES").

! **CAUTION:** it is recommended to wear the appropriate PPE (Personal Protective Equipment) for the work to be carried out.

6. Stand at the back of the machine.

Adjusting the height of the squeegee body:

7. Release the stopper lever (3) for the squeegee's height adjustment knob (4) (Fig.3).
8. Adjust the height of the rubber blade in relation to the floor by loosening or tightening the knobs (4) (Fig. 4).

i **N.B.:** Figure 4 indicates the rotation direction for decreasing the distance between the squeegee support and the floor. This distance can be increased by turning it in the opposite direction.

i **N.B.:** By decreasing the distance between the squeegee support and the floor, the rubber blades present in the squeegee body move closer to the floor.

i **N.B.:** The right-hand and left-hand knobs must be rotated the same number of times, so that the squeegee is parallel to the floor when it is working.

i **N.B.:** Make sure the adjustment is correct by looking at the instrument (5) on the squeegee body (Fig.5).

9. Once the adjustment has been completed, engage the stopper lever (4) (Fig. 7).

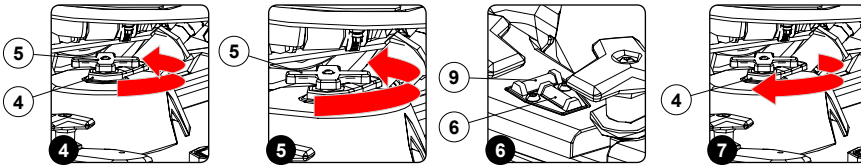

Adjusting the tilt of the squeegee body:

10. Loosen the stopper knob (7) for the squeegee's tilt adjustment knob (8) (Fig. 8).

11. Adjust the tilt of the squeegee body's rubber blades in relation to the floor, tighten or loosen the knob (8) (Fig. 9) until the squeegee body's rubber blades are bent outwards by about 30° in relation to the floor, in an even manner along their entire length.

i **N.B.:** Figure 9 indicates the direction of rotation for tilting the squeegee towards the rear of the machine (Fig. 10). Turn it in the opposite direction to rotate the squeegee towards the front of the machine.

i **N.B.:** Check for proper adjustment by looking at the instrument (9) positioned on the squeegee body (Fig. 6).

12. Once the adjustment has been completed, tighten the stopper knob (7) (Fig. 11).

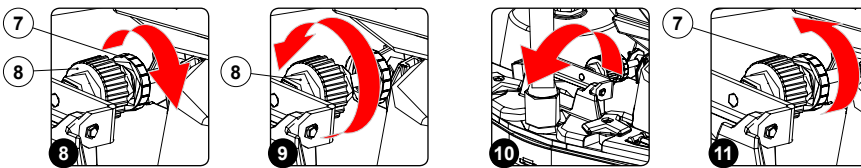

ADJUSTING THE SCRUBBING BRUSH HEAD SIDE SPLASH GUARD

If the side splash guards of the brush head body are not positioned correctly they cannot do their work properly, namely convey the dirty detergent solution towards the squeegee, therefore the height of the splash guard needs to be adjusted.

This operation can be done with the brush head body in the work position, proceeding as follows:

1. Sit on the driver's seat.
2. Insert the key (1) in the main switch on the control panel. Set the main switch to "I" (Fig. 1).
3. Using the knob (2) on the control panel (Fig. 2), select the "SCRUBBING WITH DRYING" work program.
4. Press the drive pedal (3) (Fig. 3) to begin moving the machine.

5. As soon as the brush head and the squeegee have reached their working positions, perform the procedure for securing the machine (see the chapter "[MACHINE SAFETY MEASURES](#)").

! **CAUTION:** it is recommended to wear the appropriate PPE (Personal Protective Equipment) for the work to be carried out.

6. Go to the front left-hand side of the machine.
7. Adjust the height of the splash guard with respect to the floor, tighten or loosen the knob (4) until the splash guard touches the floor along its entire length (Fig. 4).

i **N.B.:** Both the front and rear of the splash guard need to be at the same height off the floor.

8. Repeat the operations just carried out also for the right side centre as well.

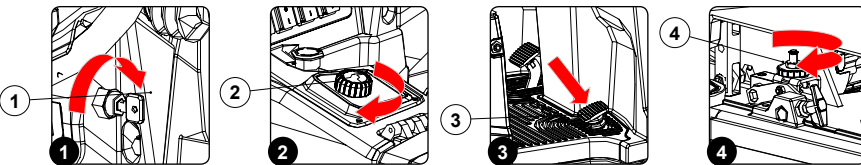

DISPOSAL

To dispose of the machine, take it to a demolition centre or an authorised collection centre. Before scrapping the machine, it is necessary to remove and separate out the following materials, then send them to the appropriate collection centres in accordance with the environmental hygiene regulations currently in force:

- Brushes
- Felt
- Electric and electronic parts*
- Batteries.
- Plastic parts.
- Metallic parts.

(*) In particular, contact your distributor when scrapping electric and electronic parts.

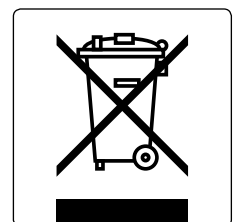

CHOOSING AND USING THE BRUSHES

POLYPROPYLENE BRUSH (PPL)

Used on all types of floors. Good resistance to wear and tear, and hot water (no greater than 50°C.). The polypropylene is non-hygroscopic and therefore retains its characteristics even when working in wet conditions.

ABRASIVE BRUSH

The bristles of this type of brush are charged with highly aggressive abrasives. It is used to clean very dirty floors. To avoid floor damage, work only with the pressure strictly necessary.

BRISTLE THICKNESS

Thicker bristles are more rigid and are therefore used on smooth floors or floors with small joints.

On uneven floors or those with deep joints, it is advisable to use softer bristles which can enter the gaps more easily.

Remember that when the bristles are worn and therefore too short, they will become rigid and are no longer able to penetrate and clean deep down. In this case, like with over-large bristles, the brush tends to jump.

PAD HOLDER

The pad holder is recommended for cleaning shiny surfaces.

There are two types of pad holder:

1. The traditional pad holder is fitted with a series of anchor points that allow the abrasive floor pad to be held and dragged while working.
2. the CENTRE LOCK type pad holder not only has anchor points, but also a snap-type central locking system in plastic that allows the abrasive floor pad to be perfectly centred and held without any risk of it becoming detached. This type of pad holder is recommended above all for machines with more than one brush, where the centring of the abrasive discs is difficult.

RED PAD

Suitable for frequent use on relatively clean floors. Even cleans without water, and polishes by removing marks.

GREEN PAD

Suitable for removing surface layers of wax and for preparing the flooring for subsequent treatments. For wet use.

BLACK PAD

Suitable for wet scraping heavy layers of wax. Removes the old finish, and eliminates burrs in concrete.

MACHINE	NO. OF BRUSHES	CODE	TYPE OF BRISTLES	Ø BRISTLES	Ø BRUSHES.	NOTES
C75 2019 B	2	414270	PPL	0.3	400 mm	BLUE BRUSH
	2	414271	PPL	0.6	400 mm	WHITE BRUSH
	2	414272	PPL	0.9	400 mm	BLACK BRUSH
	2	414273	ABRASIVE	-	400 mm	GREY BRUSH
	2	449915	NATURAL FIBRE	-	400 mm	BEIGE BRUSH
	2	405508	-	-	380mm	PAD HOLDER WITH CENTRE LOCK

TROUBLESHOOTING

This chapter lists the most common problems linked with the use of the machine. If you are unable to resolve the problems with the information given here, please contact your nearest assistance centre.

PROBLEM	POSSIBLE CAUSE	SOLUTION
The machine does not start.	The emergency switch is active.	Turn the emergency switch in the direction of the arrows printed on this to reset.
	The machine's general control board has detected an alarm.	See the " ALARM SCREEN " section and contact your nearest Comac assistance centre.
	Batteries flat..	Charge the batteries, see " RECHARGING THE BATTERIES ".
	The battery connector is disconnected from the machine's electrical system connector.	Connect the battery connector to the machine's electrical system connector; this operation must be performed by a specialised Comac technician or by a qualified worker.
	One of the cable bridges of the battery is not connected properly.	Check the battery connection; this operation must be performed by a specialised Comac technician or by a qualified worker.
	Batteries faulty.	Contact a Comac assistance centre to replace the batteries.
Detergent solution collection low or absent.	The squeegee rubber blades are worn.	Replace the squeegee body rubber blades; see " REPLACING THE SQUEEGEE BODY RUBBER BLADES ".
	The squeegee body is not properly adjusted.	Adjust the squeegee body; read the paragraph " ADJUSTING THE SQUEEGEE BODY RUBBER BLADES ".
	The squeegee body is clogged.	Clean the squeegee body; see " CLEANING THE SQUEEGEE BODY ".
	The vacuum tube is clogged.	Clean the vacuum tube; see " CLEANING THE VACUUM TUBE ".
	The vacuum tube is not connected correctly.	Connect the vacuum tube to the nozzle on the squeegee body and insert into the hole in the rear part of the recovery tank.
	The suction motor filter is obstructed.	Clean the suction motor filter; see " CLEANING THE RECOVERY TANK FILTERS ".
	The recovery tank cover is not closed correctly.	Tighten the hinges on the side of the recovery tank or check that there are no obstructions that prevent these from tightening.
The suction motor does not start.	Check which working program is in use.	Select one of the working programs from: SCRUBBING WITH DRYING or DRYING.
	Recovery tank full.	Empty the recovery tank, read the paragraph " EMPTYING THE RECOVERY TANK ".
	Recovery tank full of foam.	Empty the recovery tank, read the paragraph " EMPTYING THE RECOVERY TANK ".
		Use less detergent, or change the detergent type. Use an anti-foaming agent.
The flow of detergent solution to the brushes is too low, or absent.	Solution tank empty.	Refill the solution tank; read the paragraph " FILLING THE SOLUTION TANK ".
	Detergent solution flow deactivated.	Turn the tap control lever to the ON position. For Essential versions, check the control panel to ensure that the detergent solution flow adjustment knob is not set to position 0.
		For Bright versions, check the command display to ensure that the flow of detergent solution has not been reduced to zero.
	Detergent solution delivery lines clogged.	Rinse the machine water system.
	Water system filter clogged or blocked.	Rinse the filter cartridge, see " CLEANING THE WATER SYSTEM FILTER ".

PROBLEM	POSSIBLE CAUSE	SOLUTION
Insufficient cleaning.	Debris trapped in the brushes.	Remove the debris from the brushes, see “CLEANING THE SCRUBBING BRUSH HEAD BODY BRUSHES”
	Incorrect type of brush for the work to be carried out.	Contact a Comac assistance centre for help in choosing the type of brush to be used for the work to be performed.
	Brush bristles worn.	Replace the brushes; read the paragraph “REPLACING THE SCRUBBING BRUSH HEAD BRUSHES” .
	Excessive pressure on the brushes.	Reduce the power exerted on the brush head body.
	Battery charge level low.	Perform a full battery charge cycle, see “RECHARGING THE BATTERIES” .
Reduced working autonomy.	The battery charge is not complete.	Perform a full battery charge cycle, see “RECHARGING THE BATTERIES” .
	Batteries faulty.	Contact a Comac assistance centre for battery replacement.
	The batteries require maintenance.	Contact a Comac assistance centre for battery maintenance.
	The battery charger is faulty.	Contact a Comac assistance centre for replacement of the battery charger.

EC DECLARATION OF CONFORMITY



The undersigned manufacturer:
COMAC S.p.A.
Via Maestri del Lavoro, 13
37059 Santa Maria di Zevio (VR)
declares under its sole responsibility that the products

SCRUBBING MACHINES - mod. C75 2019 B ESSENTIAL - C75 2019 B BRIGHT

comply with the requirements of the following Directives:

- 2006/42/EC: Machinery Directive.
- 2014/30/EC: Electromagnetic compatibility directive.

They also comply with the following standards:

- EN 60335-1:2012/A11:2014
- EN 60335-2-72:2012
- EN 12100:2010
- EN 61000-6-2:2005/AC:2005
- EN 61000-6-3:2007/A1:2011/AC:2012
- EN 62233:2008/AC:2008

The person authorized to compile the technical file:

Mr. Giancarlo Ruffo
Via Maestri del Lavoro, 13
37059 Santa Maria di Zevio (VR) - ITALY

Santa Maria di Zevio (VR), 09/07/2019

Comac S.p.A.
The Legal Representative
Giancarlo Ruffo



